



STAINLESS STEEL
MODULAR HANDRAIL SYSTEMS



www.bridco.com.au



COMPANY PROFILE

Bridco is the Registered trademark of Bridge & Company Pty Ltd, which is a family owned business first established in 1984. Bridco has since grown to become one of Australia's largest importers & exporters of quality stainless steel hardware.

Originally we were predominantly involved in the importation and wholesale supply of marine hardware, but the Company has expanded to become one of the largest suppliers of stainless steel wire rope fittings and hardware to the industrial and architectural industries. Bridco also specialise in a range of stainless steel Load Rated fittings and Grade 50, stainless steel chain & components.

Our staff comprises of personnel with extensive knowledge of the marine field, industrial lifting equipment and wire rope swaging.

Our products can be found in a wide and diverse range of industries including mining, fishing, logging, the armed forces, water & wastewater treatment plants, sewerage plants, petrochemical industries, architectural and structural engineering, playground equipment and shop fittings. Our products are widely sought after for both commercial and residential applications.



PUBLICATION ERRORS

Although all care has been taken in the preparation and publication of this catalogue, the technical information including dimensions in illustrations, drawings and charts are non binding. Bridco does not accept any responsibility for any typographical or other errors which may have occurred during the production.

STAINLESS STEEL FACTS

This catalogue contains a comprehensive range of quality stainless steel modular railing systems, suitable for both interior and exterior applications as well as commercial and residential projects.

GRADES: There are many grades of stainless steel, the majority of items in this catalogue are grade 316 with some products in grade 304 and zintec.

ZINTEC: Raw uncoated steel suitable for internal or external applications. These products need to be powder coated before application.

GRADE 304: Ideally suited to indoor use only, has good corrosion resistance and is one of the most commonly used grades of stainless steel.

GRADE 316: Has a higher level of corrosion resistance, therefore is most suitable to outdoor applications and for exposed coastal applications. The grade 316 is often referred to as "marine grade".

Tea staining: Tea staining can be defined as: discoloration of the surface of stainless steel that does not effect the structural integrity or the longevity of the material.

Contributing factors.....and what can be done about them.

The relationships between the contributing factors are complex, but generally become increasingly critical closer to marine water.

Environmental factors:

Tea staining occurs most commonly within about 5 kilometers from the surf and becomes progressively worse closer to the marine source. However, wind exposure, pollution levels and high temperatures can create environments where tea staining might occur 20 kilometers or more from the sea water. These same factors also increase corrosion rates of alternative materials.

Surface finish:

Rough surface finishes promote tea staining: The smoother the surface finish the better. A surface roughness (Ra) of less than 0.5 micrometers is strongly recommended, a No:4 finish is inadequate. Typically the products in this catalogue are 320 grit or higher which achieves a finish better than 0.5 micrometers (Ra).

Maintain regularly:

Stainless steel is not maintenance free, but maintenance friendly. When using stainless steel material outdoors you need to clean periodically, especially in aggressive environments like coastal areas or swimming pools. Washing regularly will reduce the risk of tea staining. For best results wash with soap or a mild detergent and warm water, followed by rinsing with cold water. The appearance of the surface can be improved further if the washed surface is wiped dry.

We recommend Bridco B40 cleaner and B42 polish for the best maintenance results.

* Material Data sheets are provided with B40 & B42.

Installation and inspection:

After installation the completed structure should be washed and inspected for imperfections or contaminant's caused by the installation process. If discovered any imperfections should be cleaned off and polished with Bridco B40, followed by B42 polish. Hydrochloric acid should not be used on stainless steel as it will stain the surface and may start more serious corrosion.

The above notes have been researched by the Australian Stainless Steel Development Association (ASSDA) of which BRIDCO is a member.

Bridco will not be held responsible for any replacements at the time of publication. We recommend checking dimensions with our sales staff before purchasing Bridco products.

Bridco will not be held responsible for any errors, omissions or changes in dimensions at the time, or after publication of this catalogue.

CONTACT US



(07) 55 935 688

Our office hours are:
7.30am - 4.30pm



(07) 55 935 872

General Sales & Quotes

(07) 55 936 561

Sales - Lifting Equipment
& Accounts



www.bridco.com.au

Visit our website for
further details & images
of Bridco products.

bridge@bridco.com.au

Email us.

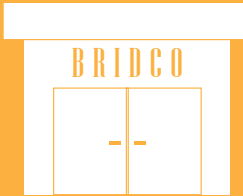

**37 Taree Street
BURLEIGH QLD 4220**

Our warehouse is
conveniently situated
just 3km from the Reedy
Creek Road exit on the
M1

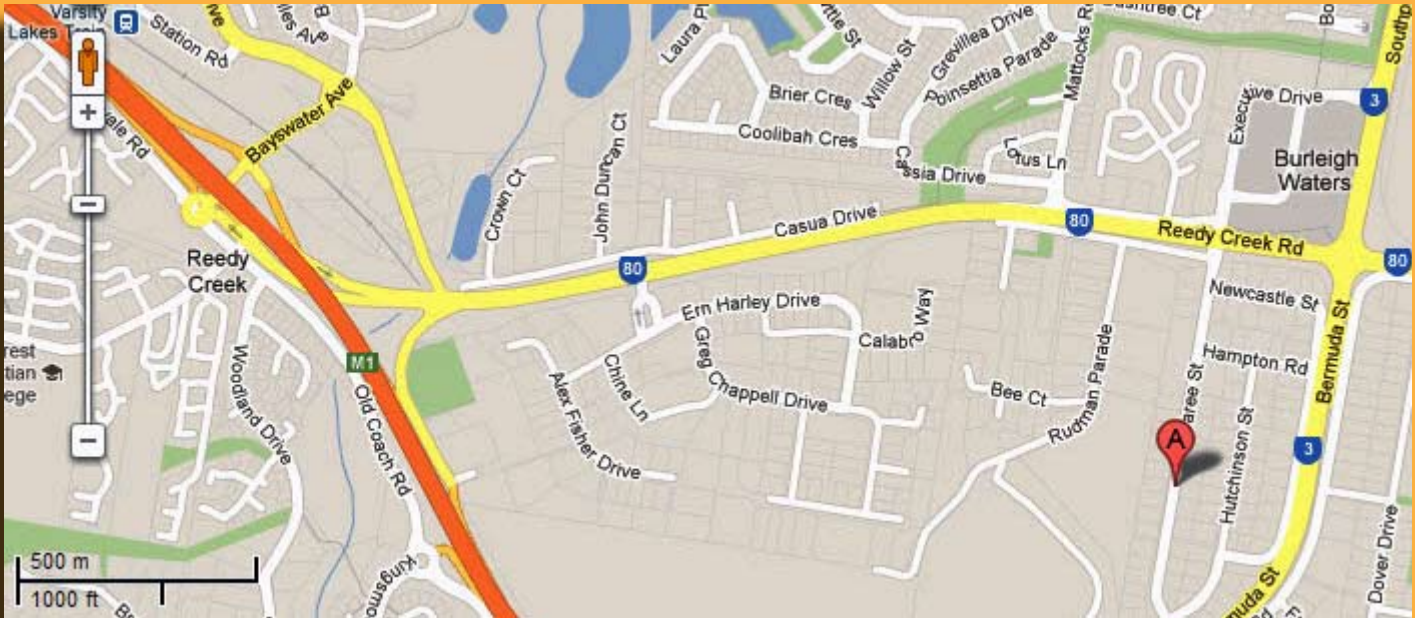

INDEX

HANDRAIL
BRACKETS

Pages 5 - 10

TUBE
FITTINGS

Pages 11 - 22

POST
FITTINGS

Pages 23 - 26

MAINTENANCE



Pages 27 - 28

ROD
HOLDERS

Pages 29 - 32



Pages 33 - 42

GLASS
CLAMPS



Pages 43 - 44

ADAPTERS &
SPIGOTS



Pages 45 - 46

CHANNEL
SYSTEMS



Pages 47 - 48

ROD &
TUBE



Pages 49 - 54

STAINLESS
FITTINGS

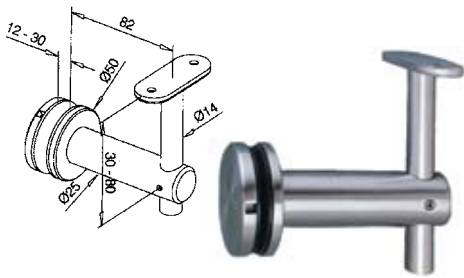

HANDRAIL BRACKET - FIXED GLASS MOUNT - FLAT HANDRAIL

CODE	RAIL DIA MM	FINISH
AN-140150000G	FLAT	SATIN
AN-140150000MG	FLAT	MIRROR

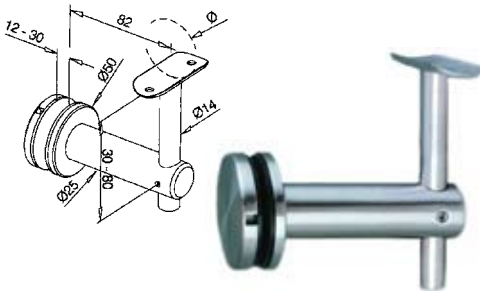

HANDRAIL BRACKET - FIXED GLASS MOUNT - ROUND HANDRAIL

CODE	RAIL DIA MM	FINISH
AN-140150048G	48.3 - 50.8	SATIN
AN-140150048MG	48.3 - 50.8	MIRROR

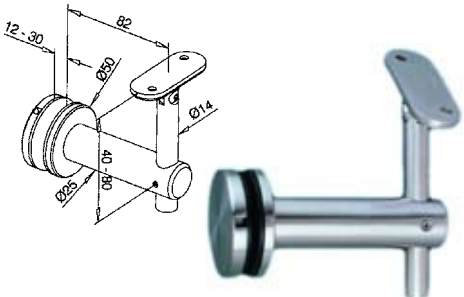

HANDRAIL BRACKET - ADJUSTABLE GLASS MOUNT - FLAT HANDRAIL

CODE	RAIL DIA MM	FINISH
AN-140155000G	FLAT	SATIN
AN-140155000MG	FLAT	MIRROR

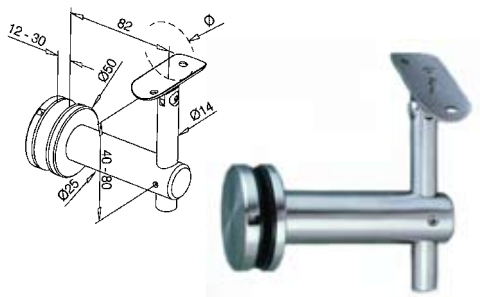

HANDRAIL BRACKET - ADJUSTABLE GLASS MOUNT - ROUND TOP RAIL

CODE	RAIL DIA MM	FINISH
AN-140155048G	48.3 - 50.8	SATIN
AN-140155048MG	48.3 - 50.8	MIRROR

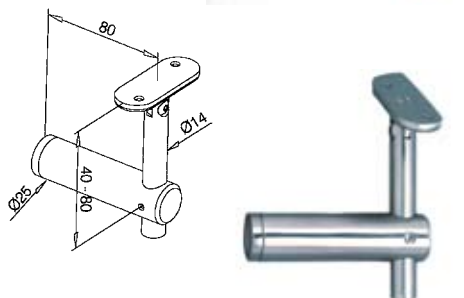

HANDRAIL BRACKET - ADJUSTABLE - FLAT RAIL

CODE	RAIL DIA MM	FINISH
AN-140133000G *	FLAT	SATIN

* DENOTES RUNOUT LINE.

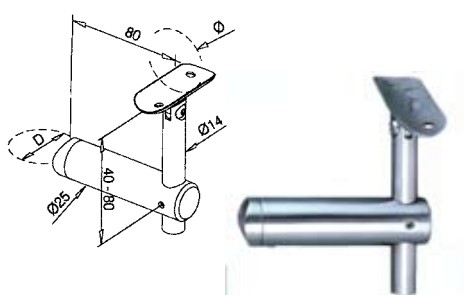

HANDRAIL BRACKET - ADJUSTABLE - ROUND RAIL

CODE	RAIL DIA MM	FINISH
AN-140136048G *	48.3 - 50.8	SATIN
AN-140136048MG *	48.3 - 50.8	MIRROR

* DENOTES RUNOUT LINE.

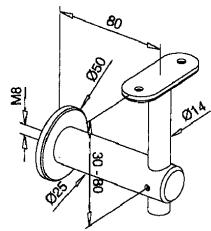

HANDRAIL BRACKET - FIXED WALL MOUNT - FLAT RAIL

CODE	RAIL DIA MM	FINISH
AN-1401400MG *	FLAT	SATIN

* DENOTES RUNOUT LINE.

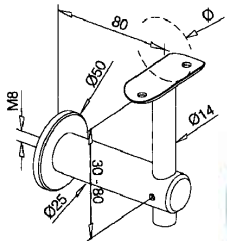

HANDRAIL BRACKET - FIXED WALL MOUNT - ROUND TOP RAIL

CODE	RAIL DIA MM	FINISH
AN-140140048G *	48.3 - 50.8	SATIN
AN-140140048MG *	48.3 - 50.8	MIRROR

* DENOTES RUNOUT LINE.

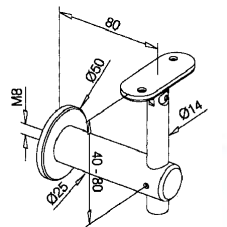

HANDRAIL BRACKET - ADJUSTABLE WALL MOUNT - FLAT RAIL

CODE	RAIL DIA MM	FINISH
AN-140145000G *	FLAT	SATIN

* DENOTES RUNOUT LINE.

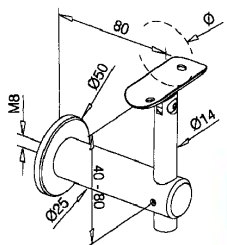

HANDRAIL BRACKET - ADJUSTABLE WALL MOUNT - ROUND TOP RAIL

CODE	RAIL DIA MM	FINISH
AN-140145048G *	48.3 - 50.8	SATIN

* DENOTES RUNOUT LINE.



HANDRAIL BRACKETS AISI 316

www.bridco.com.au

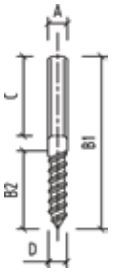

RIGHT DOUBLE THREADED COACH SCREW AISI 316

CODE	A	B1	B2	C	D
SS-78311-08	M8	100	47	40	8
SS-78311-10	M10	100	57	30	10

The above item is required for securing wall mounted Handrail brackets.
1 coach screw per bracket.

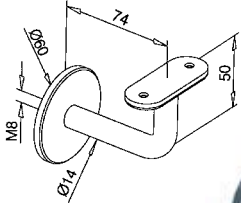

HANDRAIL BRACKET - FIXED BOLT MOUNT - FLAT RAIL

CODE	RAIL DIA MM	FINISH
AN-140111000G	FLAT	SATIN

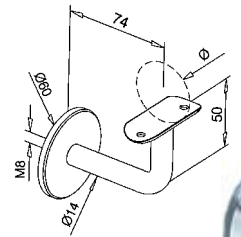

HANDRAIL BRACKET - FIXED BOLT MOUNT - ROUND RAIL

CODE	RAIL DIA MM	FINISH
AN-140111048G	48.3 - 50.8	SATIN
AN-140111048MP	48.3 - 50.8	MIRROR

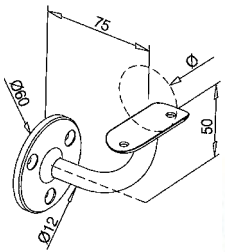

HANDRAIL BRACKET - FIXED WALL MOUNT - ROUND RAIL

CODE	RAIL DIA MM	FINISH
AN-1401112048G	48.3 - 50.8	SATIN

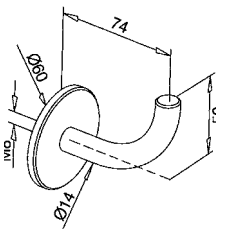

HANDRAIL BRACKET - BOLT MOUNT - WELDED RAIL

CODE	DESCRIPTION	FINISH
AN-140114000G *	WALL BRACKET	SATIN

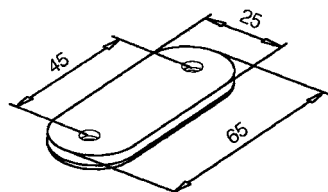

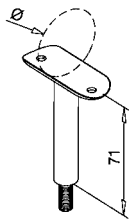

RAIL SUPPORT - FIXED - THREADED STEM - ROUND RAIL

CODE	TUBE DIA MM	FINISH
AN-140810048G	48.3 - 50.8	SATIN

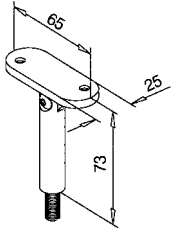

RAIL SUPPORT - ADJUSTABLE - THREADED STEM - FLAT RAIL

CODE	TUBE DIA MM	FINISH
AN-140818000G	FLAT	SATIN

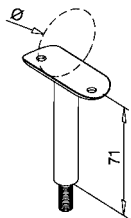

RAIL ADJUSTABLE - THREADED STEM - ROUND RAIL.

CODE	TUBE DIA MM	FINISH
AN-140818048G	48.3 - 50.8	SATIN

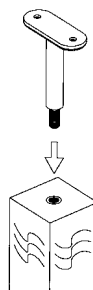

Rail supports are available with M8 or M10 threads.
Please ensure the required thread size is available prior to ordering.

HANDRAIL BRACKET - FLAT RAIL

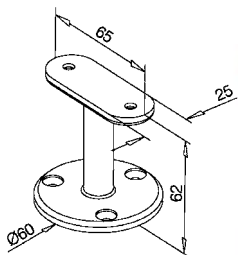

CODE	TUBE DIA MM	FINISH
AN-140708000G	FLAT	SATIN

HANDRAIL BRACKET - ROUND RAIL

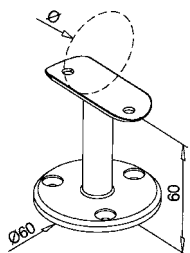

CODE	TUBE DIA MM	FINISH
AN-140708048G	48.3 - 50.8	SATIN

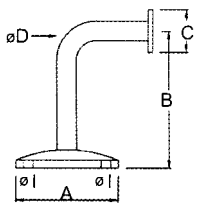

HANDRAIL SUPPORT - FIXED WALL MOUNT - FOR FLAT RAIL

CODE	A (mm)	B (mm)	C (mm)	D (mm)	I (mm)	FINISH
SR-HSWM-00	63	85	31	12	6	MIRROR

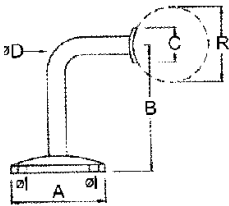

HANDRAIL SUPPORT - FIXED WALL MOUNT - FOR ROUND RAIL

CODE	A (mm)	B (mm)	C (mm)	D (mm)	I (mm)	RAIL	FINISH
SR-HSWM-50	63	85	31	12	6	2"	MIRROR

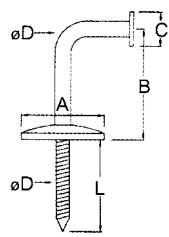

HANDRAIL SUPPORT - FIXED COACH SCREW - WALL MOUNT FOR FLAT RAIL

CODE	A (mm)	B (mm)	C (mm)	D (mm)	L (mm)	FINISH
SR-HSWMCS-00	63	85	31	12	60	MIRROR

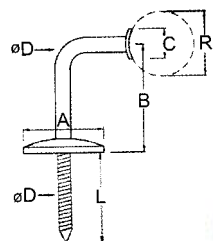

HANDRAIL BRACKET - FIXED COACH SCREW - WALL MOUNT FOR ROUND RAIL

CODE	A (mm)	B (mm)	C (mm)	D (mm)	I (mm)	RAIL	FINISH
SR-HSWMCS-50	63	85	31	12	60	2"	MIRROR

HANDRAIL BRACKET RUNOUT LINES

The components listed below will be discontinued due to low demand, once stock is depleted. These components are not featured in this catalogue but have been a part of previous publications of the 'Bridco Modular Handrail Catalogue'.

CODE	DESCRIPTION	CODE	DESCRIPTION
AN-140136000	HANDRAIL BRACKET - FIXED	AN-140708948	HANDRAIL BRACKET - FIXED 90 DEGREE
AN-140136060	HANDRAIL BRACKET - SWIVEL	AN-140708960	HANDRAIL BRACKET - FIXED 45 DEGREE
AN-140140000G	HANDRAIL BRACKET - SWIVEL	AN-140625048	HANDRAIL BRACKET
AN-140140048MG	HANDRAIL BRACKET - FIXED	AN-140114000MG	HANDRAIL BRACKET - BOLT MOUNT
AN-140145060	HANDRAIL BRACKET - ADJUSTABLE	AN-140113000G	HANDRAIL BRACKET - WALL MOUNT
AN-140810000	RAIL SUPPORT - FIXED	SR-RSP90-50	RAIL SUPPORT PLATE 90DEGREE

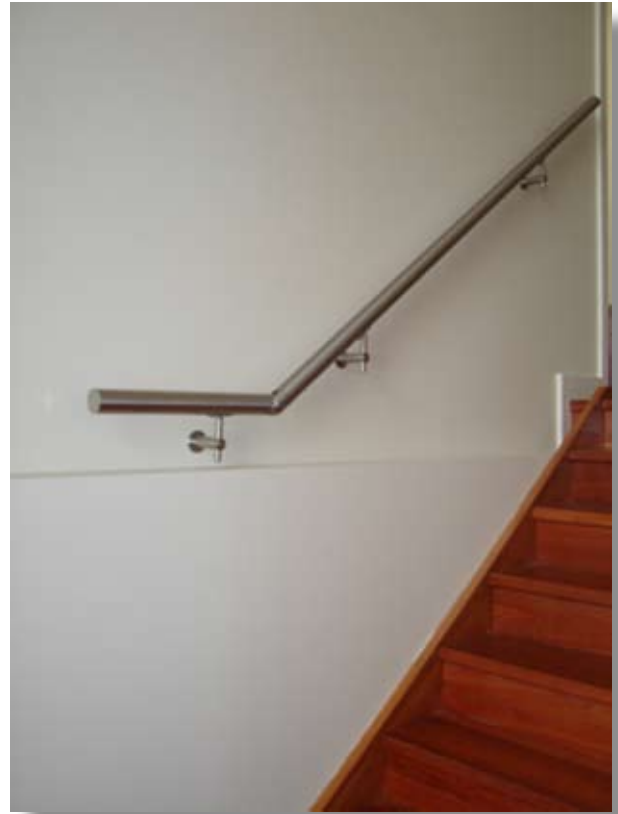

INTERIORS



The following tube fittings are for use with 48.3mm tube.

ELBOW JOINER 90 DEG.

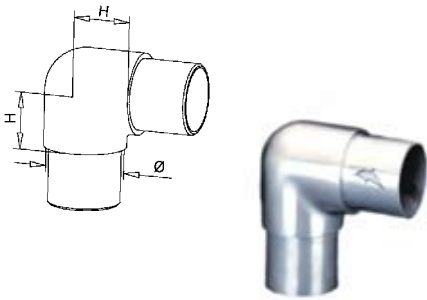

CODE	Ø = TUBE DIA mm	H	FINISH
AN-140303048G *	48.3 X 2.6	35	SATIN

* DENOTES RUNOUT LINE.

ADJUSTABLE ELBOW JOINER

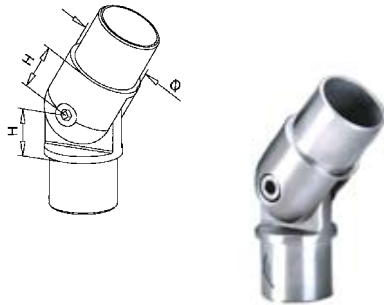

CODE	Ø = TUBE DIA mm	H	FINISH
AN-140302048G	48.3 X 2.6	30	SATIN

ELBOW JOINER - CORNER POST + RAIL

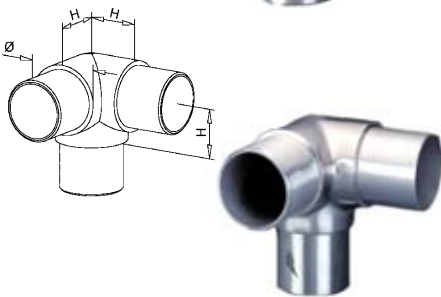

CODE	Ø = TUBE DIA mm	H	FINISH
AN-140304048G	48.3 X 2.6	35	SATIN

ELBOW - 135DEGREE

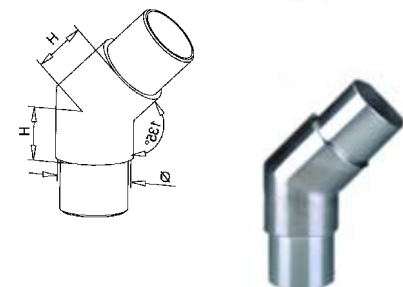

CODE	Ø = TUBE DIA MM	H	FINISH
AN-140300048 *	48.3 X 2.6	35	SATIN

* DENOTES RUNOUT LINE.

RAIL SUPPORT - ROUND RAIL

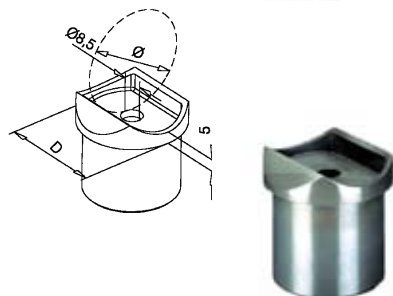

CODE	D = POST	Ø = RAIL DIA	FINISH
AN-140726048G *	48.3 X 2.6	48.3	SATIN

* DENOTES RUNOUT LINE.

RAIL END CAP - DOMED

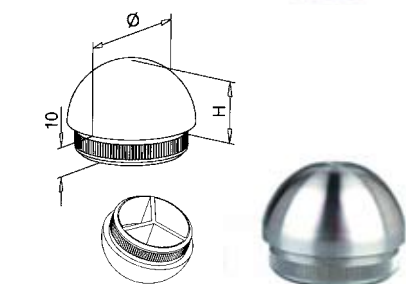

CODE	TUBE DIA MM	H	FINISH
AN-145730048 *	48.3 X 2.6	24	SATIN

* DENOTES RUNOUT LINE.

RAIL END CAP - FLAT

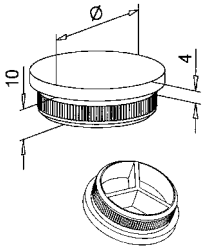

CODE	Ø	FINISH
AN-145732048G *	48.3 X 2.6	SATIN

* DENOTES RUNOUT LINE.

RAIL SUPPORT - FIXED - FLAT RAIL

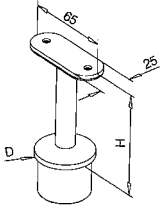

CODE	D = POST	H	FINISH
AN-140711000 *	48.3 X 2.6	82	SATIN

* DENOTES RUNOUT LINE.

RAIL SUPPORT - FIXED 90 DEG - ROUND RAIL

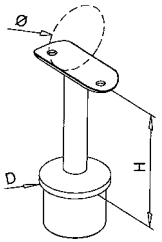

CODE	D = POST	Ø	H	FINISH
AN-140711048 *	48.3 X 2.6	48.3	80	SATIN

* DENOTES RUNOUT LINE.

RAIL SUPPORT - FIXED 90DEGREE - ROUND RAIL

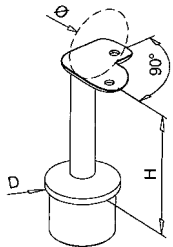

CODE	D = POST	Ø	H	FINISH
AN-140711948 *	48.3 X 2.6	48.3	80	SATIN

* DENOTES RUNOUT LINE.

RAIL SUPPORT - ADJUSTABLE - FLAT RAIL

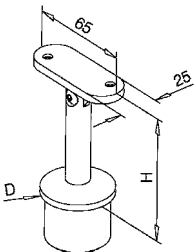

CODE	D = POST	H	FINISH
AN-140719000 *	48.3 X 2.6	82	SATIN

* DENOTES RUNOUT LINE.

RAIL SUPPORT - ADJUSTABLE - ROUND RAIL

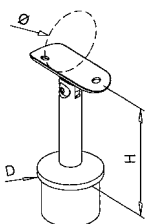

CODE	D = POST	Ø	H	FINISH
AN-140719048MP *	48.3 X 2.6	48.3	80	MIRROR

* DENOTES RUNOUT LINE.

The following tube fittings are for use with 50.8mm/2" tube.

END CAP - ARCHED

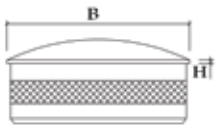

CODE	TUBE	WALL (mm)	B (mm)	H (mm)	FINISH
SR-EC-50	2"	1.6	50.8	2	MIRROR
SR-EC-50S	2"	1.6	50.8	2	SATIN

END CAP - FLAT

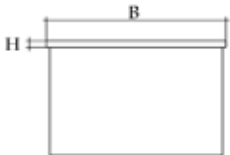

CODE	TUBE	WALL (mm)	B (mm)	H (mm)	FINISH
SR-ECF-50	2"	1.6	50.8	4	MIRROR

END CAP - DOMED

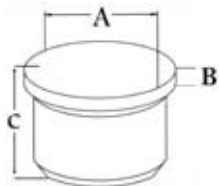

CODE	TUBE	WALL (mm)	A (mm)	B (mm)	C (mm)	FINISH
SR-ECD-50	2"	1.6	50.8	2	22	MIRROR

HANDRAIL END 90 DEGREE

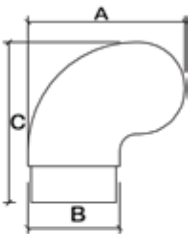

CODE	TUBE	WALL (mm)	A (mm)	B (mm)	C (mm)	FINISH
SR-HE90D-50	2"	1.6	89	50.8	89	MIRROR



The following tube fittings are for use with 50.8mm/2" tube.

HANDRAIL END 45 DEGREE

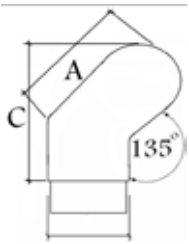

CODE	TUBE	WALL (mm)	A (mm)	B (mm)	RAIL (mm)	FINISH
SR-HE45D-50	2"	1.6	70	50.8	1.6	MIRROR

FLUSH ELBOW - ADJUSTABLE

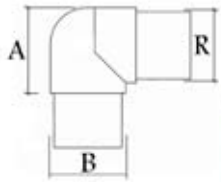

CODE	TUBE	WALL (mm)	A (mm)	B (mm)	RAIL (mm)	FINISH
SR-AE-50	2"	1.6	57	50.8	1.6	MIRROR

FLUSH ELBOW - FIXED - 90 DEGREE

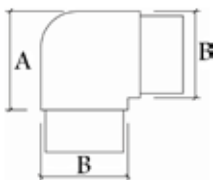

CODE	TUBE	WALL (mm)	A (mm)	B (mm)	RAIL (mm)	FINISH
SR-FE-50	2"	1.6	57	50.8	1.6	MIRROR

FLUSH ELBOW - RADIUSSED - 90 DEGREE

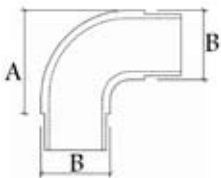

CODE	TUBE	WALL (mm)	A (mm)	B (mm)	RAIL (mm)	FINISH
SR-FER-50	2"	1.6	66	50.8	1.6	MIRROR

FLUSH JOINER - IN LINE

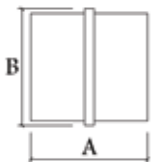

CODE	TUBE	WALL (mm)	A (mm)	B (mm)	FINISH
SR-FJ-50	2"	1.6	54	50.8	MIRROR

FLUSH JOINER - 135 DEGREE

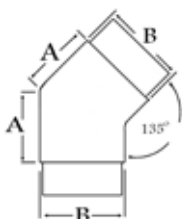

CODE	TUBE	WALL (mm)	A (mm)	B (mm)	FINISH
SR-FJ135-50	2"	1.6	45	50.8	MIRROR

The following tube fittings are for use with 50.8mm/2" tube.

FLUSH JOINER TEE

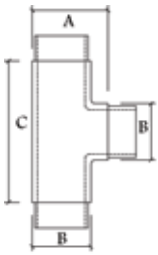

CODE	TUBE	WALL (mm)	A (mm)	B (mm)	C (mm)	FINISH
SR-FJT-50	2"	1.6	57	50.8	67	MIRROR

FLUSH JOINER TEE - 90 DEGREE

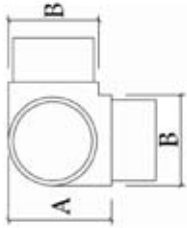

CODE	TUBE	WALL (mm)	A (mm)	B (mm)	FINISH
SR-FJT90-50	2"	1.6	57	50.8	MIRROR

FLUSH JOINER TEE - 4 WAY

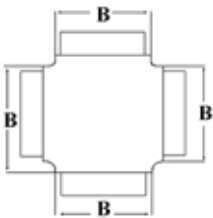

CODE	TUBE	WALL (mm)	C (mm)	B (mm)	FINISH
SR-FJT4WAY-50 *	2"	1.6	57	50.8	MIRROR

* DENOTES RUNOUT LINE.

RAIL SUPPORT - ADJUSTABLE - WALL MOUNT

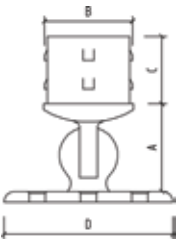

CODE	TUBE	WALL (mm)	A (mm)	B (mm)	C (mm)	D (mm)	FINISH
SR-ARSWM-50 *	2"	1.6	51	50.8	26	101	MIRROR

* DENOTES RUNOUT LINE.

RAIL SUPPORT - ADJUSTABLE - FOR ROUND HANDRAIL

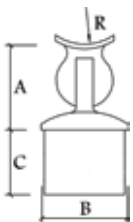

CODE	TUBE	WALL (mm)	A (mm)	B (mm)	C (mm)	R (mm)	FINISH
SR-ARS-50	2"	1.6	51	50.8	32	50.8	MIRROR

RAIL SUPPORT - ADJUSTABLE - FOR FLAT HANDRAIL

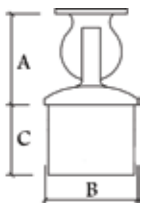

CODE	TUBE	WALL (mm)	A (mm)	B (mm)	C (mm)	FINISH
SR-ARSF-50	2"	1.6	51	50.8	32	MIRROR

The following tube fittings are for use with 50.8mm/2" tube.

RAIL SUPPORT - ADJUSTABLE - EXTERNAL FIT

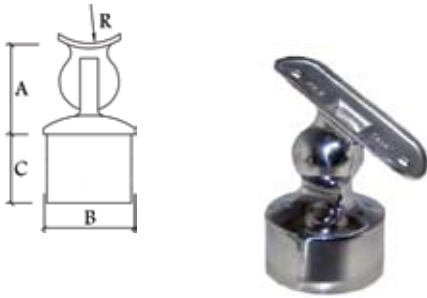

CODE	TUBE	WALL (mm)	A (mm)	B (mm)	C (mm)	R (mm)	FINISH
SR-ARSEXT-50	2"	1.6	51	50.8	32	50.8	MIRROR
SR-ARSEXTF-50	2"	1.6	51	50.8	32	FLAT	MIRROR

RAIL SUPPORT - ADJUSTABLE TAPPERED - FOR ROUND HANDRAIL

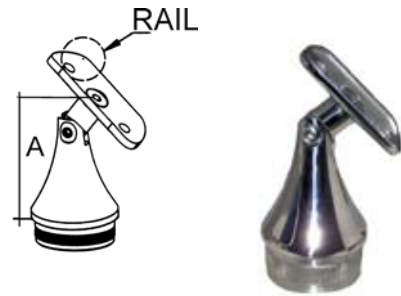

CODE	TUBE	WALL (mm)	A (mm)	RAIL (mm)	FINISH
SR-RSTH-50	2"	1.6	78.6	50.8	MIRROR

RAIL SUPPORT

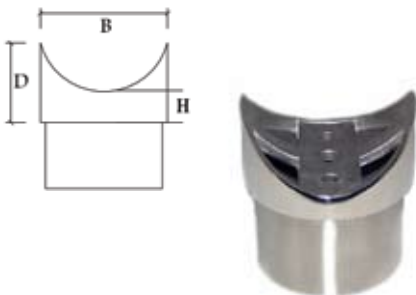

CODE	TUBE	WALL (mm)	A (mm)	B (mm)	H (mm)	RAIL (mm)	FINISH
SR-RS-50	2"	1.6	32	51	10.5	50.8	MIRROR

RAIL SUPPORT - EXTERNAL FIT - 37 DEGREE - FOR ROUND HANDRAIL

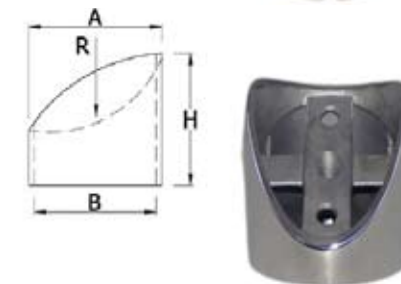

CODE	TUBE	A (mm)	B (mm)	C (mm)	RAIL (mm)	FINISH
SR-RSEC37-50	2"	56	51.4	56	50.8	MIRROR
SR-RSEC37-25 *	1"	28.5	25.6	32	50.8	MIRROR

RAIL SUPPORT - EXTERNAL FIT - FOR ROUND HANDRAIL

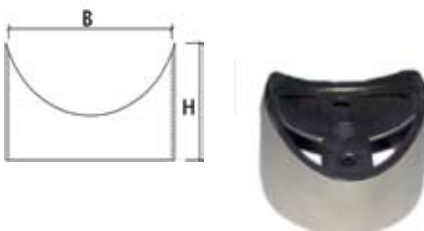

CODE	TUBE	B (mm)	H (mm)	R = RAIL (mm)	FINISH
SR-RSEC-50	2"	51.5	39	50.8	MIRROR
SR-RSEC-25 *	1"	26	17	50.8	MIRROR

* DENOTES RUNOUT LINE.

RAIL SUPPORT - EXTERNAL CAP - EXPANDING 37 DEGREE

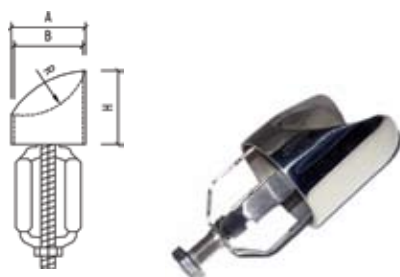

CODE	TUBE	A (mm)	B (mm)	H (mm)	R (mm)	FINISH
SR-RSEXP37-50 *	2"	56	51	56	50.8	MIRROR

* DENOTES RUNOUT LINE.

The following tube fittings are for use with 50.8mm/2" tube.

RAIL SUPPORT - FOR FLAT HANDRAIL

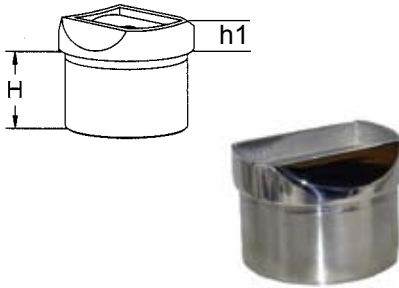

CODE	TUBE	WALL (mm)	RAIL (mm)	H (mm)	h1 (mm)	FINISH
SR-RSF-50 *	2"	1.6	FLAT	25	12	MIRROR

* DENOTES RUNOUT LINE.

RAIL SUPPORT - FOR ROUND HANDRAIL



CODE	TUBE	WALL (mm)	RAIL (mm)	H (mm)	h1 (mm)	FINISH
SR-RSR-50	2"	1.6	50.8	25	8	MIRROR

BRIDCO USER GUIDE & CONDITIONS OF USE FOR STAINLESS STEEL COMPONENTS.

Bridco have published a four page brochure containing important information for users of stainless steel components.

The user guide cover such issues as cleaning & maintenance, stainless steel grades, corrosion resistance & environmental factors.

Bridco recommend reading this guide before purchasing or selling stainless steel fittings and / or components.

To obtain a copy of the user guide please contact our sales department, alternatively a copy can be downloaded by visiting our website: www.bridco.com/links.html

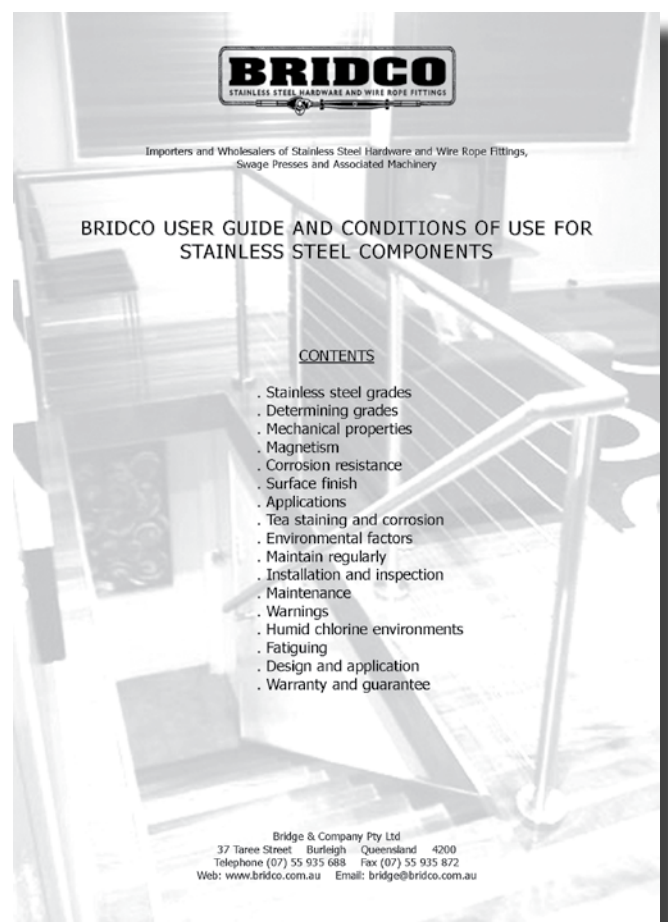

The following tube fittings are for use with 50.8mm/2" tube.

RAIL SUPPORT CAP - DOMED



CODE	TUBE	WALL (mm)	H (mm)	O (mm)	FINISH
SR-RSCD-50	50.8	1.6	M8	2"	MIRROR

COUNTER SUNK SOCKET SCREW



CODE	THREAD	THREAD LENGTH
SS-CSS6010	M6	10

RAIL SUPPORT STEM - FIXED / SWIVEL

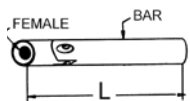
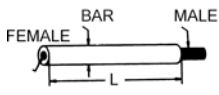

CODE	BAR DIA (mm)	THREAD FEMALE	THREAD MALE	L (mm)	FINISH
SR-RSSF-40	14	M6	M8	40	MIRROR
SR-RSSS-40	14	M6	M8	40	MIRROR
SR-RSSS-75	14	M6	M8	75	MIRROR

RAIL SUPPORT PLATE - FOR FLAT HANDRAIL

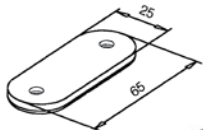

CODE	RAIL	FINISH
SR-RSP-00	FLAT	MIRROR

RAIL SUPPORT PLATE - FOR ROUND HANDRAIL

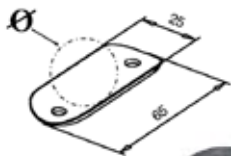

CODE	RAIL	FINISH
SR-RSP-50	50.8	MIRROR

The components above make up this handrail bracket with the option of a support plate for a flat or round handrail.

Choose the stem and rail support plate to suit your application.

All components must be ordered individually.



The following tube fittings are for use with 50.8mm/2" tube.

ADJUSTABLE RAIL SUPPORT - FLAT RAIL

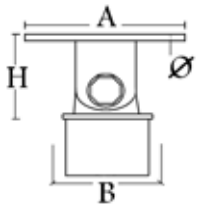

CODE	TUBE	WALL (mm)	A (mm)	B (mm)	H (mm)	I (mm)	FINISH
SR-SQ40112	2"	1.5mm	66	50.8	50	6	MIRROR
SR-SQ40112S	2"	1.5mm	66	50.8	50	6	SATIN

END CAP - FLAT

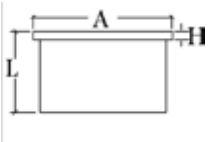

CODE	TUBE	WALL (mm)	A (mm)	H (mm)	L (mm)	FINISH
SR-SQ30112	2"	1.5mm	50.8	3	33	MIRROR

FLUSH JOINER - "IN LINE"

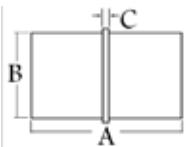

CODE	TUBE	WALL (mm)	A (mm)	B (mm)	C (mm)	FINISH
SR-SQ10712	2"	1.5mm	66	50.8	6	MIRROR

FLUSH JOINER - TEE

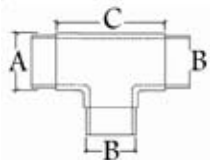

CODE	TUBE	WALL (mm)	A (mm)	B (mm)	C (mm)	FINISH
SR-SQ10312	2"	1.5mm	60	50.8	75	MIRROR

FLUSH JOINER - 90DEG TEE

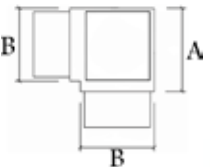

CODE	TUBE	WALL (mm)	A (mm)	B (mm)	FINISH
SR-SQ10512	2"	1.5mm	63	50.8	MIRROR

FLUSH JOINER - 90DEG



CODE	TUBE	WALL (mm)	A (mm)	B (mm)	FINISH
SR-SQ10112	2"	1.5mm	63	50.8	MIRROR

TUBE FITTINGS RUNOUT LINES

The components listed below will be discontinued due to low demand, once stock is depleted. These components are not featured in this catalogue but have been a part of previous publications of the 'Bridco Modular Handrail Catalogue'.

CODE	DESCRIPTION	CODE	DESCRIPTION
AN-140303060	ELBOW - 90 DEG - 60MM	AN-140711048MP	RAIL SUPPORT
AN-140301048	ELBOW - 90 DEGREE	AN-140711960	RAIL SUPPORT
AN-11801020	ELBOW - 3 WAY ADJUSTABLE	AN-140719048MP	RAIL SUPPORT
AN-11801030	ELBOW - 3 WAY ADJUSTABLE	AN-140719060	RAIL SUPPORT
AN-140307048	T - JOINER	AN-140739048	RAIL END
AN-140790048	FLUSH JOINER	AN-145729048MP	POST CAP
AN-140790048MP	FLUSH JOINER	AN-140729060	POST CAP
AN-140790060	FLUSH JOINER	AN-145729048G	POST CAP
AN-10504000	RAIL SUPPORT	SR-ARS3WAY-50	ADJUSTABLE RAIL SUPPORT
AN-10504048	RAIL SUPPORT	SR-EC-50/1.5	END CAP
AN-10505000	RAIL SUPPORT	SR-FJT135-50	FLUSH JOINER TEE
AN-10505048	RAIL SUPPORT	SR-FJS4WAY-50	FLUSH JOINER STAR
AN-140726000	RAIL SUPPORT	SR-RSP90-50	RAIL SUPPORT PLATE
AN-140726048MP	RAIL SUPPORT	SR-RSSF-75	RAIL SUPPORT STEM
AN-140726060	RAIL SUPPORT	SR-RSSS-75	RAIL SUPPORT STEM

ULTRALOC RETAINING COMPOUND

Ultraloc is a high strength performance retaining compound for slip fitted parts. Ideal for gap filling up to 0.15mm.

For application surfaces should be dry, clean & free of any contamination. Adhesive should be applied to the part in sufficient quantity to fill the gaps.



CODE	TUBE	WALL (mm)
MS-3680-10	Retaining compound	10ml
MS-3680-50	Retaining compound	50ml



DESIGN





E X T E R I O R S



The following post fittings are for use with 48.3mm tube.

BASE PLATE WITH RUBBER RING

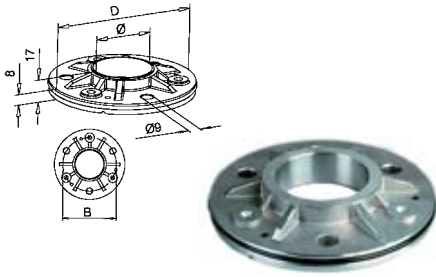

CODE	Ø	B (mm)	D (mm)	FINISH
AN-143502048G*	48.3	90	115	SATIN

*DENOTES RUN OUT LINE

BASE PLATE

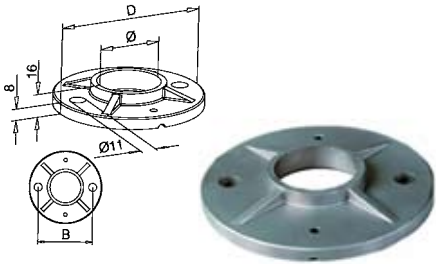

CODE	Ø	B (mm)	D (mm)	FINISH
AN-140940048G*	48.3	75	100	SATIN

*DENOTES RUN OUT LINE

BASE PLATE COVER

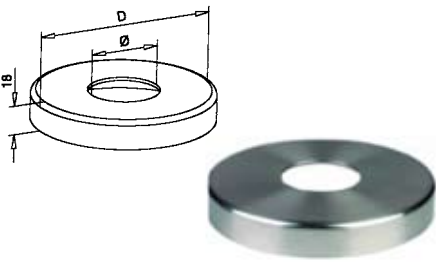

CODE	Ø	D (mm)	FINISH
AN-140512048G*	50	105	SATIN

*DENOTES RUN OUT LINE

BASE PLATE COVER

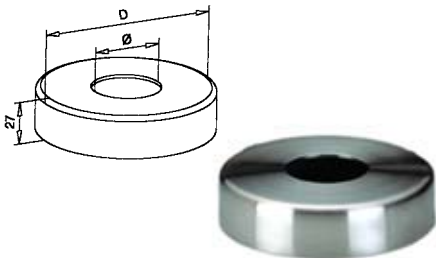

CODE	Ø	D (mm)	FINISH
AN-140511048G*	50	120	SATIN

*DENOTES RUN OUT LINE

POST FLANGE

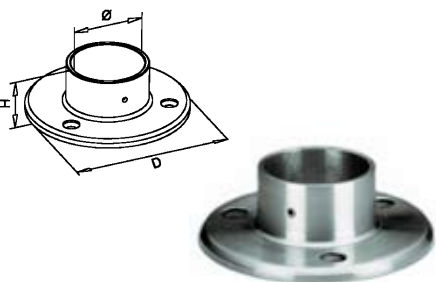

CODE	Ø	D (mm)	FINISH
AN-140505048G*	48.3	100	SATIN

*DENOTES RUN OUT LINE



The following post fittings are for use with 50.8mm / 2" tube.

BASE PLATE FLANGE - ROUND BASE

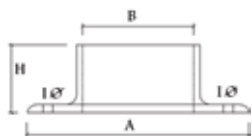

CODE	TUBE	A (mm)	B (mm)	H (mm)	I (mm)	FINISH
SR-BPFR-50	2"	102	50.8	31	9	MIRROR
SR-BPFRX-50	2"	102	50.8	31	9	MIRROR

X - Indicates flange without grub screw.

BASE PLATE FLANGE - OBLONG BASE

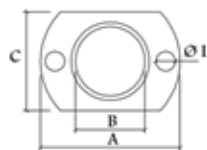

CODE	TUBE	A (mm)	B (mm)	H (mm)	I (mm)	C (mm)	FINISH
SR-BPF0-50	2"	100	50.8	31	9	70	MIRROR
SR-BPFOX-50	2"	100	50.8	31	9	70	MIRROR

X - Indicates flange without grub screw.

BASE PLATE FLANGE - OBLONG BASE - 37 DEGREE

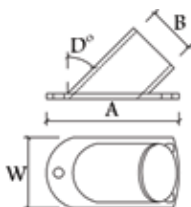

CODE	TUBE	D (mm)	A (mm)	B (mm)	W (mm)	I (mm)	FINISH
SR-BPF037-50	2"	37	110	50.8	70	6	MIRROR

BASE PLATE - HEAVY DUTY - WELD ON

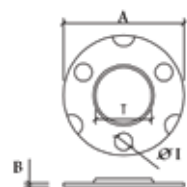

CODE	TUBE	A (mm)	B (mm)	I (mm)	T (mm)	FINISH
SR-BPHD-50	2"	100	8	9	51	SATIN

BASE PLATE / WELD ON

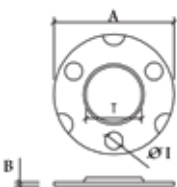

CODE	TUBE	A (mm)	B (mm)	I (mm)	T (mm)	FINISH
SR-BP-50	2"	100	3	8.5	51	SATIN

BASE PLATE COVER - ARCHED

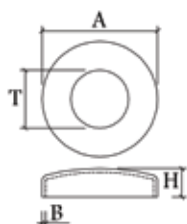

CODE	TUBE	A (mm)	B (mm)	H (mm)	T (mm)	FINISH
SR-BPC-50	2"	102	0.8	26	51	MIRROR

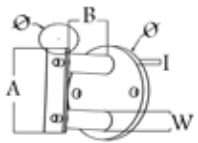

POST WALL BRACKET / ROUND POST

CODE	TUBE	A (mm)	B (mm)	W (mm)	I (mm)	FINISH
SR-PWB-50 *	2"	89.5	50	20	5.5	MIRROR

*DENOTES RUN OUT LINE

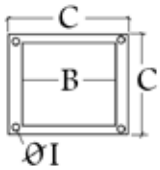

BASE PLATE FLANGE - SQUARE BASE

CODE	TUBE	WALL (mm)	B (mm)	C (mm)	H (mm)	I (mm)	FINISH
SR-SQ20512	2"	1.5mm	50.8	100	30	8	MIRROR



BASE PLATE FLANGE - OBLONG BASE

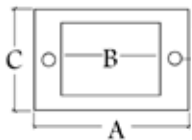

CODE	TUBE	WALL (mm)	A (mm)	B (mm)	C (mm)	H (mm)	I (mm)	FINISH
SR-SQ20112	2"	1.5mm	116	50.8	80	30	8	MIRROR

POST FITTINGS RUNOUT LINES

The components listed below will be discontinued due to low demand, once stock is depleted. These components are not featured in this catalogue but have been a part of previous publications of the 'Bridco Modular Handrail Catalogue'.

CODE	DESCRIPTION	CODE	DESCRIPTION
AN-143510048	HEAVY DUTY BASE	AN-140913048MP	POST - HEAVY DUTY
AN-143511048	HEAVY DUTY BASE	SR-BPCB-50	BASE PLATE COVER TYPE B
AN-140544048	POST - STAIR THREAD	SR-BPB-50	BASE PLATE - TYPE B





HANDRAILS



Maintenance.

Stainless steel is not maintenance free, but maintenance friendly. When using stainless steel material outdoors you need to clean periodically, especially in aggressive environments like coastal areas or swimming pools. Washing regularly will reduce the risk of tea staining. For best results wash with soap or a mild detergent and warm water, followed by rinsing with cold water. The appearance of the surface can be improved further if the washed surface is wiped dry.

We recommend Bridco B40 cleaner and B42 polish for the best maintenance results,(see page 29).

For high salt or commercial applications G316 with a high or mirror polish should be used.

Satin finished products require extra maintenance especially in high salt environments. Rough surface finishes promote tea staining: The smoother the surface finish, the better. A surface roughness (Ra) of less than 0.5 micrometres is strongly recommended.

Further treatments such as passivating or electrolyzing will also promote better corrosion resistance.

Please note that modular hand rail fittings, open body turnbuckles etc , in their design, also require more regular maintenance due to gaps and crevices that trap foreign contaminants.

Stainless Steel maintenance of external applications.

Rainfall on a regular basis will remove dirt, dust and other deposits from stainless steel if the design of the facade allows. In most parts of Australia however, there is often insufficient rainfall to effectively clean external fittings, Bridco therefore recommend the use of the cleaning schedule below.

Stainless Steel Cleaning Schedule.

Environment	Distance from beachfront or sheltered bay	Cleaning interval
Mild	15km+	Every 12 months
Moderate	1 - 15km	Every 4-6 months
Marine/Industrial/Urban	500m - beachfront / 100m - 1km - sheltered bay	Every 3 months
Sever Marine/Industrial/Busy Urban	500m - beachfront / 100m - sheltered bay	Weekly

BRIDCO USER GUIDE & CONDITIONS OF USE FOR STAINLESS STEEL COMPONENTS.



Bridco have published a four page brochure containing important information for users of stainless steel components.

The user guide covers such issues as cleaning & maintenance, stainless steel grades, corrosion resistance & environmental factors.

Bridco recommend reading this guide before purchasing or selling stainless steel fittings and/or components.

To obtain a copy of the Bridco user guide please contact our sales department, alternatively a copy can be downloaded by visiting our website: www.bridco.com.au/links.html



BRIDCO CLEANER

B40 stainless steel cleaner is a mixture of acids, selected solvents and surfactants specially designed to remove tea staining and grout from stainless steel stanchions, rails, stainless steel wire rope etc. B40 will not corrode stainless steel nor will it turn green or brown as hydrochloric based cleaners will.

*A hazardous goods surcharge of +50% is applied to all freight costs for B40.

Standard box contains 6 x 500ml spray bottles (Hazardous Cargo). 20 litre containers also available.

BRIDCO POLISH



B42 Stainless steel cleaner is specially designed to remove tea staining and fine scratches from stainless steel railings and fittings, etc.

B42 deposits a protective low surface energy, water resistant layer which repels water and air borne contaminants for several months before re-application may be required.

Standard box contains 15 x 250ml bottles.

*Material Data sheets are provided with B40 & B42.



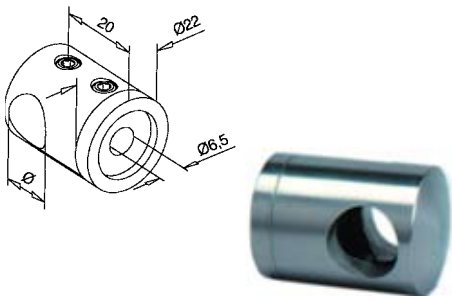

ROD HOLDER - FLAT POST - 12mm

CODE	Ø (mm)	FINISH
AN-140830000G	12	SATIN

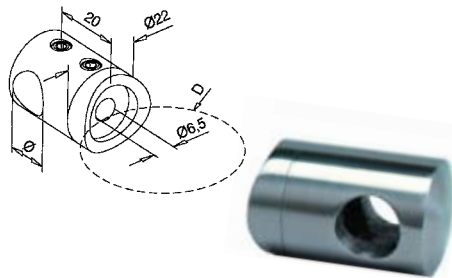

ROD HOLDER - ROUND POST - 12mm

CODE	Ø (mm)	D (mm)	FINISH
AN-140830048G	12	48.3-50.8	SATIN
AN-140830048MG	12	48.3-50.8	MIRROR
AN-140830150MG	12.7	48.3-50.8	MIRROR

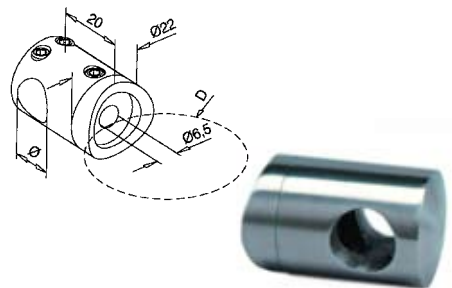

ROD HOLDER - FLAT POST - 12mm

CODE	Ø (mm)	D (mm)	FINISH
AN-140831048G	12	48.3-50.8	SATIN

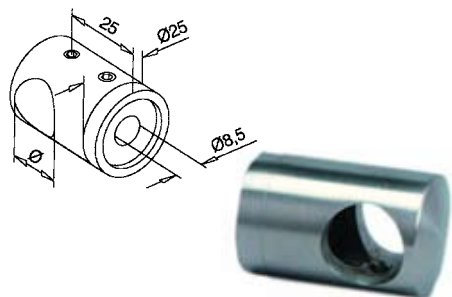

ROD HOLDER - FLAT POST - 16mm

CODE	Ø (mm)	FINISH
AN-140840000MG *	16	MIRROR

* DENOTES RUN OUT ITEM

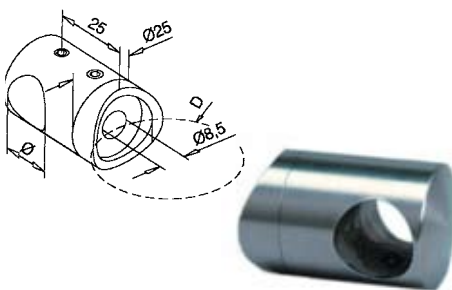

ROD HOLDER - ROUND POST - 16mm

CODE	Ø (mm)	D (mm)	FINISH
AN-140840048G *	16	48.3 - 50.8	MIRROR
AN-140840048MG *	16	48.3 - 50.8	MIRROR

* DENOTES RUN OUT ITEM

INFORMATION

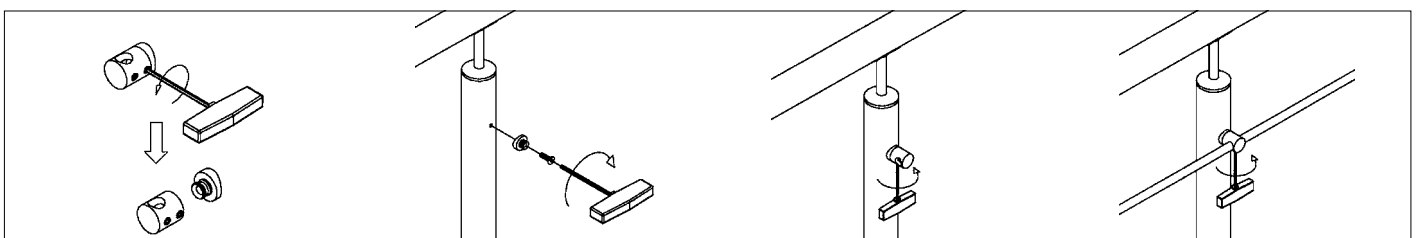

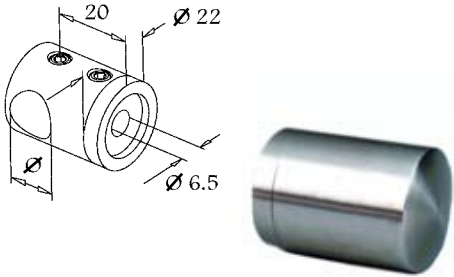

ROD HOLDER - LEFT END - FLAT POST - 12mm

CODE	Ø (mm)	FINISH
AN-140832000G*	12	SATIN

* DENOTES RUN OUT ITEM

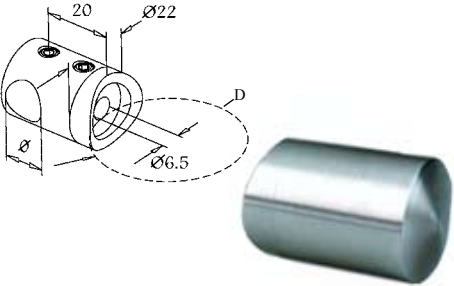

ROD HOLDER - LEFT END - ROUND POST - 12mm & 12.7mm

CODE	Ø	D (mm)	FINISH
AN-140832048G	12	48.3-50.8	SATIN
AN-140832150MG	12.7	48.3-50.8	MIRROR

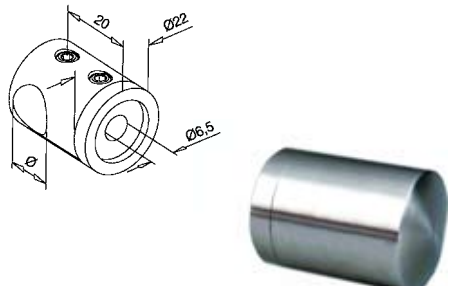

ROD HOLDER - RIGHT END - FLAT POST - 12mm

CODE	Ø	FINISH
AN-140833000G*	12	SATIN

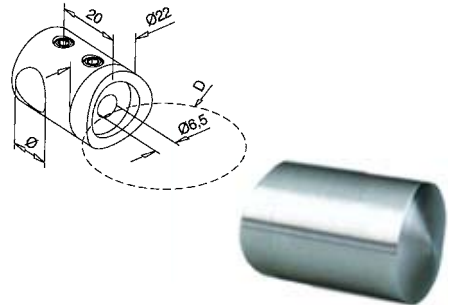

ROD HOLDER - RIGHT END - ROUND POST - 12mm - 12.7mm

CODE	Ø	D (mm)	FINISH
AN-140833048G	12	48.3-50.8	SATIN
AN-140833150MG	12.7	48.3-50.8	MIRROR



AN-140830150MG / CENTRE



AN-140833150MG / RIGHT



AN-140832150MG / LEFT

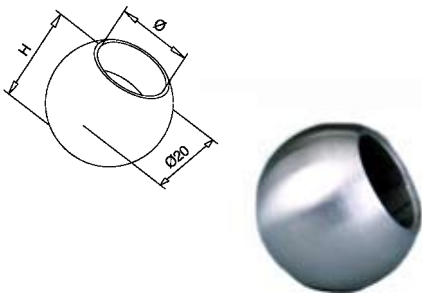

BALL END FOR 12mm ROD

CODE	Ø	H	FINISH
AN-140221012	12	c.a 17.5	SATIN

ROD HOLDER RUNOUT LINES

The components listed below will be discontinued due to low demand, once stock is depleted. These components are not featured in this catalogue but have been a part of previous publications of the 'Bridco Modular Handrail Catalogue'.

CODE	DESCRIPTION	CODE	DESCRIPTION
AN-140831000	ROD HOLDER 12mm FOR FLAT POST	AN-140840000	ROD HOLDER 16mm FOR FLAT POST

CLEANING & MAINTENANCE



BRIDCO STAINLESS STEEL CLEANER

CODE	DESCRIPTION	SIZE
SR-B40	STAINLESS STEEL CLEANER	500ml
SR-B40B	STAINLESS STEEL CLEANER / BULK	20ltr



BRIDCO STAINLESS STEEL POLISH

CODE	DESCRIPTION	SIZE
SR-B42	STAINLESS STEEL POLISH	250ml





BALUSTRADE



GLASS CLAMP - "D" SHAPE - FLAT POST



CODE	T = GLASS WIDTH	FINISH
AN-1420-00	6mm, 8mm	SATIN

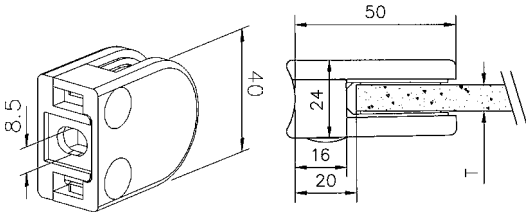

CODE	DESCRIPTION	PER CLAMP
SS-SOCM820	HEX SCREW M8 X 20mm	1



GLASS CLAMP - "D SHAPE" - FLAT POST



CODE	T = GLASS WIDTH	FINISH
AN-1422-00G	6mm, 8mm, 10mm	SATIN

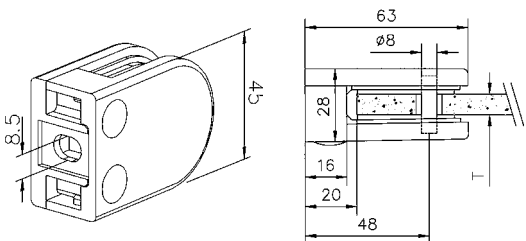

CODE	DESCRIPTION	PER CLAMP
SS-SOCM820	HEX SCREW M8 X 20mm	1



CODE	DESCRIPTION	PER CLAMP
AN-195015022	SECURITY PIN	1

GLASS CLAMP - "D" SHAPE - ROUND POST



CODE	T = GLASS WIDTH (mm)	POST (mm)	FINISH
AN-1422-48G	6mm, 8mm, 10mm	48.3 - 50.8	SATIN

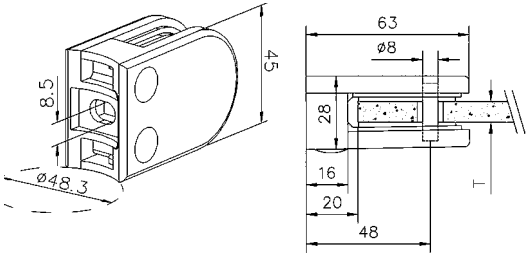

CODE	DESCRIPTION	PER CLAMP
SS-SOCM820	HEX SCREW M8 X 20mm	1



CODE	DESCRIPTION	PER CLAMP
AN-195015022	SECURITY PIN	1

GLASS CLAMP - "D" SHAPE - FLAT POST



CODE	GLASS WIDTH	FINISH
AN-1425-00G *	12mm	SATIN

* DENOTES RUN OUT ITEM

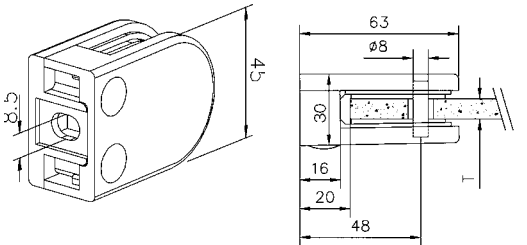

CODE	DESCRIPTION	PER CLAMP
SS-SOCM820	HEX SCREW M8 X 20mm	1



CODE	DESCRIPTION	PER CLAMP
AN-195015025	SECURITY PIN	1

GLASS CLAMP - "D" SHAPE - ROUND POST



CODE	T = GLASS WIDTH (mm)	POST (mm)	FINISH
AN-1425-48G *	12mm	48.3 - 50.8	SATIN

* DENOTES RUN OUT ITEM

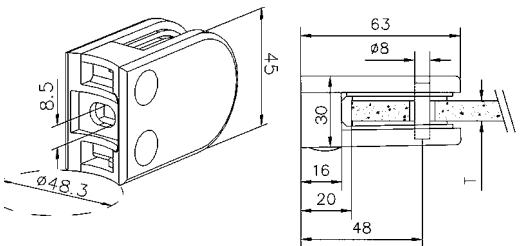

CODE	DESCRIPTION	PER CLAMP
SS-SOCM820	HEX SCREW M8 X 20mm	1



CODE	DESCRIPTION	PER CLAMP
AN-195015025	SECURITY PIN	1

GLASS CLAMP - "D SHAPE" - ROUND POST



CODE	GLASS WIDTH	FINISH
AN-1020-42G *	6mm, 8mm	ZINTEC

* DENOTES RUN OUT ITEM

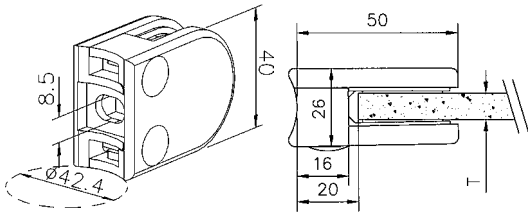

CODE	DESCRIPTION	PER CLAMP
SS-SOCM820	HEX SCREW M8 X 20mm	1

GLASS CLAMP - "D" SHAPE - ROUND POST



CODE	GLASS WIDTH (mm)	POST (mm)	FINISH
AN-1022-48G*	6mm, 8mm, 10mm	48.3 - 50.8	ZINTEC

* DENOTES RUN OUT ITEM

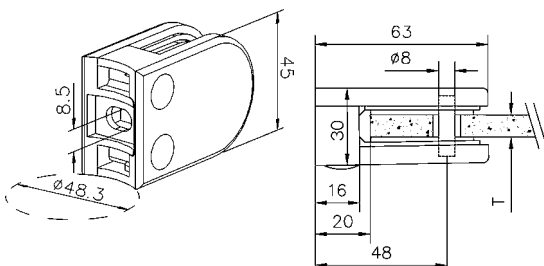

CODE	DESCRIPTION	PER CLAMP
SS-SOCM820	HEX SCREW M8 X 20mm	1



CODE	DESCRIPTION	PER CLAMP
AN-195015022	SECURITY PIN	1



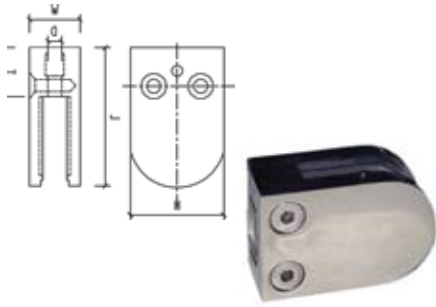

GLASS CLAMP - "D" SHAPE - FLAT POST

CODE	GLASS WIDTH	POST	H mm	L mm	W mm	T mm	D mm	Finish
SR-GCM-00	6, 8, 10mm	FLAT	45	63	26	16	9	MP
SR-GCDL-00	8, 10, 12mm	FLAT	55	32	16	9	MP	



CODE	DESCRIPTION	PER CLAMP
SS-SOCM820	HEX SCREW M8 X 20mm	1

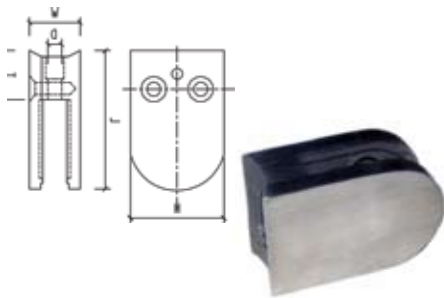

GLASS CLAMP - "D SHAPE" - ROUND POST

CODE	GLASS WIDTH	POST	H mm	L mm	W mm	T mm	D mm	Finish
SR-GCM-50	6, 8, 10mm	50.8	45	63	26	16	9	MP
SR-GCM-50S	6, 8, 10mm	50.8	45	63	26	16	9	SATIN
SR-GCDL-50	8, 10, 12mm	50.8	55	60	32	16	9	MP



CODE	DESCRIPTION	PER CLAMP
SS-SOCM820	HEX SCREW M8 X 20mm	1



GLASS CLAMP - SQUARE - FLAT POST



CODE	T = GLASS WIDTH	FINISH
AN-1426-00G	8mm, 10mm, 12mm	SATIN

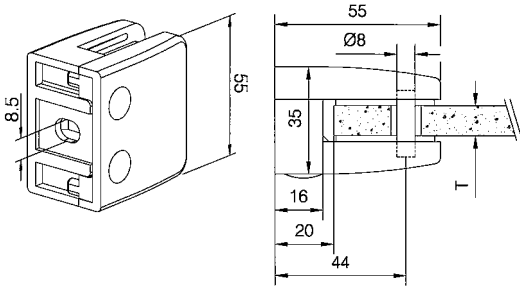

CODE	DESCRIPTION	PER CLAMP
SS-SOCM820	HEX SCREW M8 X 20mm	1



CODE	DESCRIPTION	PER CLAMP
AN-195015025	SECURITY PIN	1

GLASS CLAMP - SQUARE - ROUND POST

CODE	T = GLASS WIDTH	FINISH
AN-1426-48G	8mm, 10mm, 12mm	SATIN

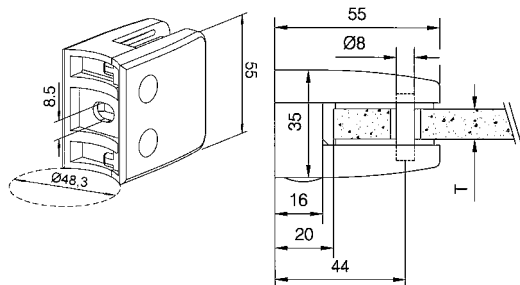

CODE	DESCRIPTION	PER CLAMP
SS-SOCM820	HEX SCREW M8 X 20mm	1



CODE	DESCRIPTION	PER CLAMP
AN-195015025	SECURITY PIN	1

GLASS CLAMP - SQUARE - ROUND POST

CODE	T = GLASS WIDTH (mm)	POST (mm)	FINISH
AN-1424-48	12mm, 16mm	48.3 - 50.8	SATIN

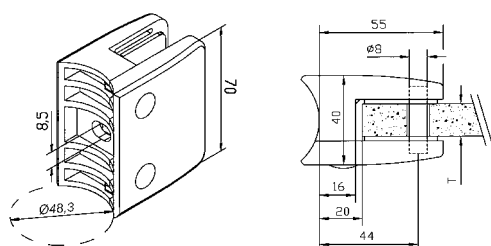

CODE	DESCRIPTION	PER CLAMP
SS-SOCM820	HEX SCREW M8 X 20mm	1



CODE	DESCRIPTION	PER CLAMP
AN-195015030	SECURITY PIN	1

GLASS CLAMP - SQUARE - ROUND POST



CODE	T = GLASS WIDTH	FINISH
AN-1021-42G *	6mm, 8mm, 10mm	ZINTEC

* DENOTES RUN OUT ITEM

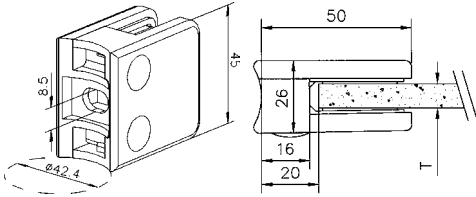

CODE	DESCRIPTION	PER CLAMP
SS-SOCM820	HEX SCREW M8 X 20mm	1

GLASS CLAMP - SQUARE - FLAT POST



CODE	T = GLASS WIDTH	FINISH
AN-1024-00G *	12mm, 16mm	ZINTEC

* DENOTES RUN OUT ITEM

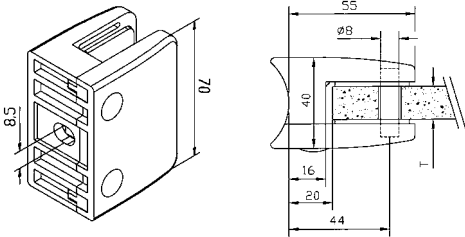

CODE	DESCRIPTION	PER CLAMP
SS-SOCM820	HEX SCREW M8 X 20mm	1



CODE	DESCRIPTION	PER CLAMP
AN-195015030	SECURITY PIN	1

GLASS CLAMP - "D" SHAPE - ROUND POST



CODE	T = GLASS WIDTH (mm)	POST (mm)	FINISH
AN-1024-48 *	12mm, 16mm	48.3 - 50.8	ZINTEC

* DENOTES RUN OUT ITEM

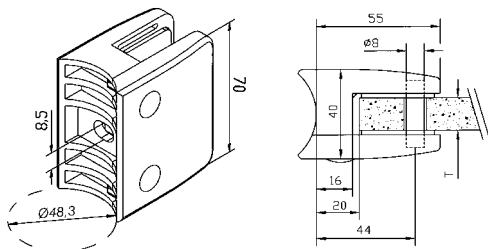

CODE	DESCRIPTION	PER CLAMP
SS-SOCM820	HEX SCREW M8 X 20mm	1



CODE	DESCRIPTION	PER CLAMP
AN-195015030	SECURITY PIN	1

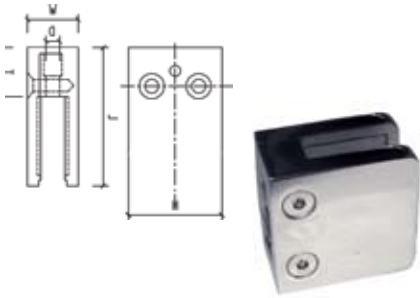

GLASS CLAMP - SQUARE - FLAT POST

CODE	GLASS WIDTH	POST	H mm	L mm	W mm	T mm	D mm	Finish
SR-GCSQ-00	8, 10, 12mm	FLAT	55	55	32	16	9	MP
SR-GCSQ-00S	8, 10, 12mm	FLAT	55	55	32	16	9	SATIN
SR-GCSQ-00SM	6, 8mm	FLAT	45	45	28	16	9	MP



CODE	DESCRIPTION	PER CLAMP
SS-SOCM820	HEX SCREW M8 X 20mm	1

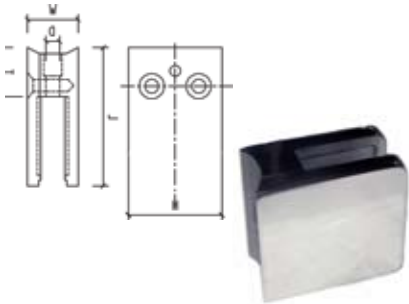

GLASS CLAMP - SQUARE - ROUND POST

CODE	GLASS WIDTH	POST	H mm	L mm	W mm	T mm	D mm	Finish
SR-GCSQ-50	8, 10, 12mm	50.8	55	55	32	16	9	MP
SR-GCSQ-50S	8, 10, 12mm	50.8	55	55	32	16	9	SATIN
SR-GCSQ-50SM	6, 8mm	50.8	45	45	28	16 <td 9	MP	



CODE	DESCRIPTION	PER CLAMP
SS-SOCM820	HEX SCREW M8 X 20mm	1



GLASS CLAMP - ROUND - FLAT & ROUND POST



CODE		GLASS WIDTH	FINISH
AN-1440-00	FLAT	8, 10, & 12mm	SATIN
AN-1440-42 *	Ø42	8, 10, & 12mm	SATIN
AN-1440-48	Ø48 - Ø50	8, 10, & 12mm	SATIN



CODE	DESCRIPTION	PER CLAMP
SS-SOCM820	HEX SCREW M8 X 20mm	1

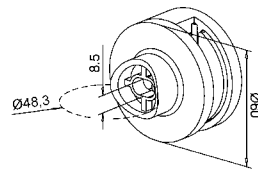
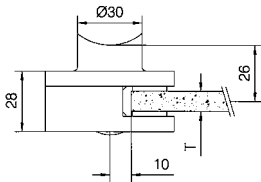
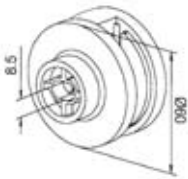

GLASS CLAMP - ROUND - FLAT & ROUND POST



CODE		GLASS WIDTH	FINISH
AN-1441-00	FLAT	8, 10, & 12mm	SATIN
AN-1441-42 *	Ø42	8, 10, & 12mm	SATIN
AN-1441-48	Ø48 - Ø50	8, 10, & 12mm	SATIN



CODE	DESCRIPTION	PER CLAMP
SS-SOCM820	HEX SCREW M8 X 20mm	1

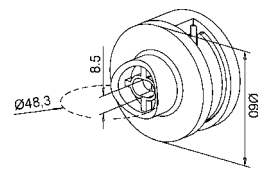
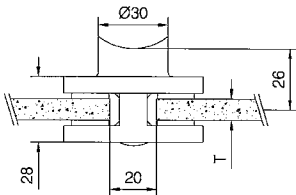
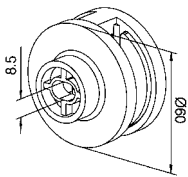

GLASS CLAMP GASKETS

www.bridco.com.au



The glass clamps in this catalogue require rubber gaskets to ensure the glass can be secured safely.

The tables below are a guide to rubber gaskets, glass clamps & glass diameter.



CODE	FOR GLASS CLAMP	GLASS DIA	PER CLAMP
AN-1420R-06	AN-1420-00	6mm	2
AN-1420R-08	AN-1420-00	8mm	2
AN-1422R-06	AN-1422-00G / AN-1422-48G	6mm	2
AN-1422R-08G	AN-1422-00G / AN-1422-48G	8mm	2
AN-1422R-10G	AN-1422-00G / AN-1422-48G	10mm	2
AN-1425R-12G	AN-1425-00G / AN-1425-48G	12mm	2



CODE	FOR GLASS CLAMP	GLASS DIA	PER CLAMP
AN-1426R-08	AN-1426-00G / AN-1426-48G	8mm	2
AN-1426R-10G	AN-1426-00G / AN-1426-48G	10mm	2
AN-1426R-12G	AN-1426-00G / AN-1426-48G	12mm	2
AN-1424R-16	AN-1424-48	16mm	2



CODE	FOR GLASS CLAMP	GLASS DIA	PER CLAMP
AN-1440R-08	AN-1440-00/42/48 AN-1441-00G/42/48G	8mm	2 4
AN-1440R-10	AN-1440-00/42/48 AN-1441-00G/42/48G	10mm	2 4
AN-1440R-12G	AN-1440-00/42/48 AN-1441-00G/42/48G	12mm	2 4



CODE	FOR GLASS CLAMP	GLASS DIA	PER CLAMP
SR-GCSQR-08	SR-GCSQ-00/50/00S/50S	8mm	2
SR-GCSQR-10	SR-GCSQ-00/50/00S/50S	10mm	2
SR-GCSQR-12	SR-GCSQ-00/50/00S/50S	12mm	2
SR-GCSQRS-06	SR-GCSQ-00SM/50SM	6mm	2
SR-GCSQR-08	SR-GCSQ-00SM/50SM	8mm	2



CODE	FOR GLASS CLAMP	GLASS DIA	PER CLAMP
SR-GCMR-06	SR-GCM-00/50/50S	6mm	2
SR-GCMR-08	SR-GCM-00/50/50S	8mm	2
SR-GCMR-10	SR-GCM-00/50/50S	10mm	2
SR-GCMR-12	SR-GCDL-00/50	12mm	2

GLASS CLAMP RUNOUT LINES

The components listed below will be discontinued due to low demand, once stock is depleted. These components are not featured in this catalogue but have been a part of previous publications of the 'Bridco Modular Handrail Catalogue'.

CODE	DESCRIPTION	CODE	DESCRIPTION
AN-1421-00G	SQUARE GLASS CLAMP / FLAT POST	AN-1427-00	"D" SHAPED MINI GLASS CLAMP
AN-1421-42	SQUARE GLASS CLAMP / ROUND POST	AN-1427R-06	6mm GASKET
AN-1421R-06	6mm GASKET	AN-1427R-08	8mm GASKET
AN-1421R-08	8mm GASKET	AN-1424R-12	12mm GASKET
AN-1421R-10	10mm GASKET	AN-1422R-08Z	8mm GASKET
AN-1026-00G	ZINTEC SQUARE CLAMP / FLAT POST	AN-1424R-12	12mm GASKET
AN-1426R-08	8mm GASKET	AN-1426R-12G	12mm GASKET
AN-1426R-10G	10mm GASKET		

POOL GATE ACCESSORIES

As a part of our Modular Handrail Systems range, Bridco have stainless steel pool gate hinges and locks.

POOL GATE HINGES



CODE	DESCRIPTION
SS-HINGE	STAINLESS STEEL GATE HINGE (pair)
SS-HINGE/SQ	STAINLESS STEEL HINGE TO SUIT SQUARE POST (pair)

POOL GATE LOCKS



CODE	DESCRIPTION
SS-LOCK	POOL GATE LOCK
SS-PGL 180	POOL GATE LOCK / GLASS FRICTION (slim line)
SS-PGL CORNER	POOL GATE LOCK / 90 deg CORNER LATCH (slim line)
SS-PGL ROUND	POOL GATE LOCK TO SUIT 50mm ROUND POST (slim line)
SS-PGL - SQUARE	POOL GATE LOCK TO SUIT SQUARE POST (slim line)

GLASS ADAPTER - FLAT SURFACES

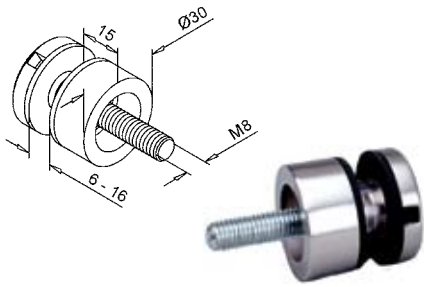

CODE	SURFACE	FINISH
AN-140746000G	FLAT	SATIN

GLASS ADAPTER - ROUND SURFACES

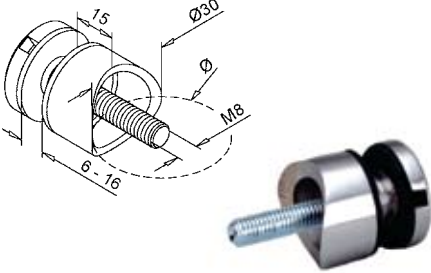

CODE	SURFACE	FINISH
AN-140746048G	48mm TUBE	SATIN

GLASS ADAPTER - FLAT SURFACES

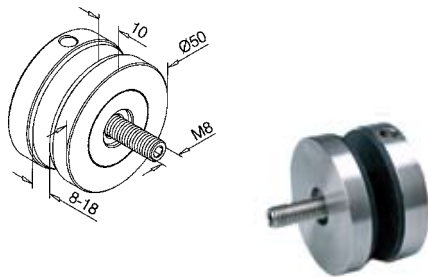

CODE	SURFACE	FINISH
AN-140747000G	FLAT	SATIN

GLASS ADAPTER - ROUND SURFACES

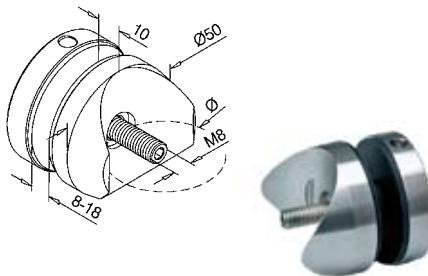

CODE	SURFACE	FINISH
AN-140747048G	48mm TUBE	SATIN

SHEET CLAMP FOR FLAT POST

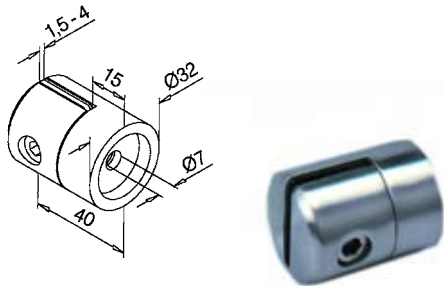

CODE	DESCRIPTION	FINISH
AN-140744000	SIGNAGE CLAMP	SATIN

SHEET CLAMP FOR ROUND POST

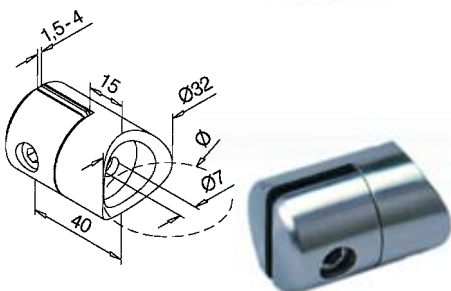

CODE	DESCRIPTION	FINISH
AN-140744048	SIGNAGE CLAMP	SATIN

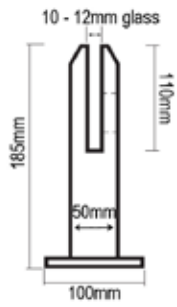

STAINLESS STEEL SPIGOT - BASE PLATE MOUNT

CODE	GLASS DIAMETER	FINISH
SR-SPIGBP-50	10-12mm	MIRROR POLISH

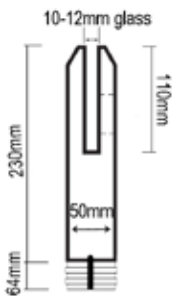

STAINLESS STEEL SPIGOT - CORE DRILL MOUNT

CODE	GLASS DIAMETER	FINISH
SR-SPIGCD-50	10-12mm	MIRROR POLISH

Drilling of glass is not required for the above spigots.

GLASS FENCING



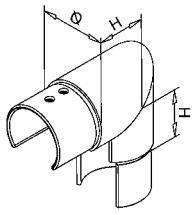

ELBOW - 90 DEGREE

CODE	ø	H	FINISH
AN-146303048G	48.3mm x 1.5mm	35	SATIN

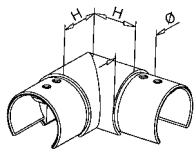

CORNER - 90 DEGREE

CODE	ø	H	FINISH
AN-146313048G	48.3mm x 1.5mm	35	SATIN
AN-146313048MG	48.3mm x 1.5mm	35	MIRROR

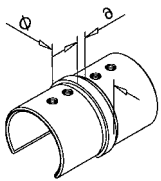

CONNECTOR

CODE	ø	FINISH
AN-146790048G	48.3mm x 1.5mm	SATIN

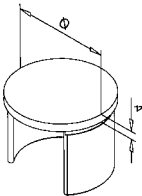

ENDCAP

CODE	ø	FINISH
AN-146732048G	48.3mm x 1.5mm	SATIN

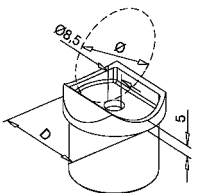

UNIVERSAL FITTING

CODE	D	ø	FINISH
AN-146726048G	48.3mm x 1.5mm	48.3	SATIN
AN-146726048MG	48.3mm x 1.5mm	48.3	MIRROR



GLASS ADAPTER / FLAT SURFACES

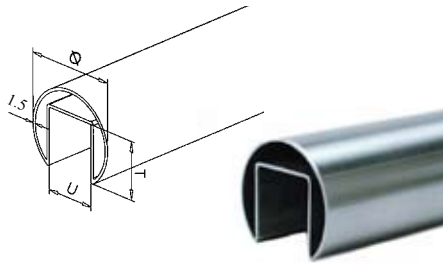

CODE	U	T	LENGTH	FINISH
AN-146920048G	27	30	5000mm	SATIN
AN-146920048MG	27	30	5000mm	MIRROR

GLASS ADAPTER - ROUND SURFACES

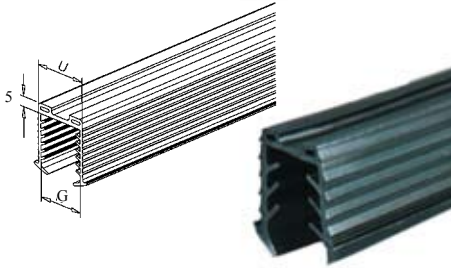

CODE	U	G
AN-195048008	27	8-11mm
AN-195048011G	27	11.5 - 13.5mm
AN-195048016G	27	16 - 17.5mm

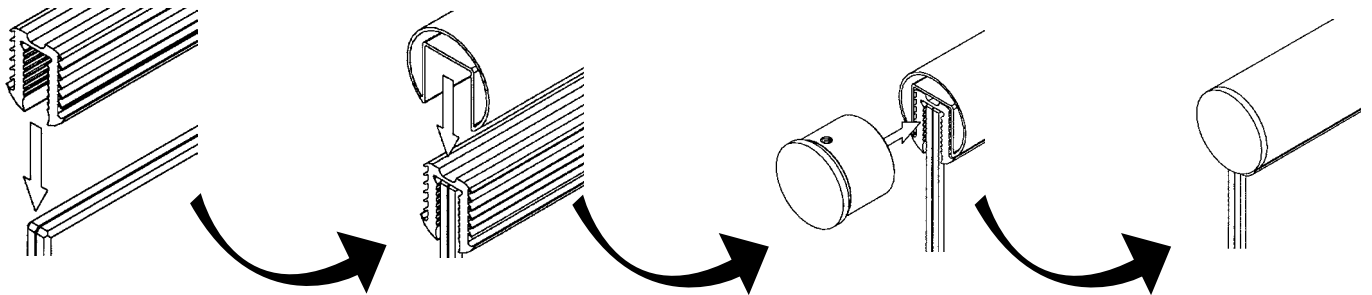

STAINLESS STEEL ROD

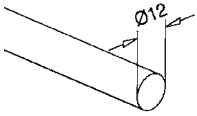

CODE	DIAMETER	FINISH
AN-1409000120G	5000mm	SATIN

STAINLESS STEEL TUBE

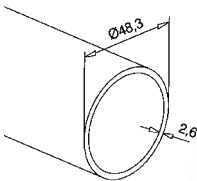

CODE	DIAMETER	FINISH
AN-140900048G	5000mm	SATIN

STAINLESS STEEL TUBE

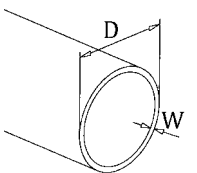

CODE	DESCRIPTION	WALL mm	L	DIAMETER mm
SR-TUBE	2" M/POLISH TUBE	1.55	6000mm	50.8
SR-TUBEHD	2" M/POLISH TUBE	2	6000mm	50.8
SR-TUBE-25	1" M/POLISH TUBE	1.5	6000mm	25
SR-TUBE-12	1/2" M/POLISH TUBE	1.2	6000mm	12.7

SR-TUBE = INTERMEDIATE POSTS
SR-TUBEHD = SUPPORT POSTS

STAINLESS STEEL TUBE - SQUARE

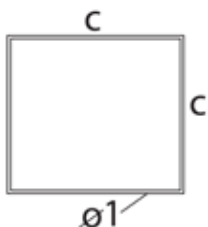

CODE	DESCRIPTION	IØ	L	C
SR-SQTUBE	2" M/POLISH SQTUBE	1.6	6000mm	50.8

Stainless steel tube is available in both 5000mm & 6000mm lengths. Please ensure the correct length is available prior to ordering.

ROD & TUBE RUNOUT LINES

The components listed below will be discontinued due to low demand, once stock is depleted. These components are not featured in this catalogue.

CODE	DESCRIPTION	CODE	DESCRIPTION
AN-140903048	90 DEG BEND	AN-1409000120	33.7mm STAINLESS STEEL TUBE
AN-140906048	180 DEG BEND	AN-140900233	60mm STAINLESS STEEL TUBE

DISPLAY UNITS



Bridco can design and assemble counter display and floor display units to suit your individual needs. Small units can be assembled prior to delivery and larger units partially assembled to allow for packaging and delivery. Final assembly would be required once unit was delivered.

EXHIBITION PARTITIONS

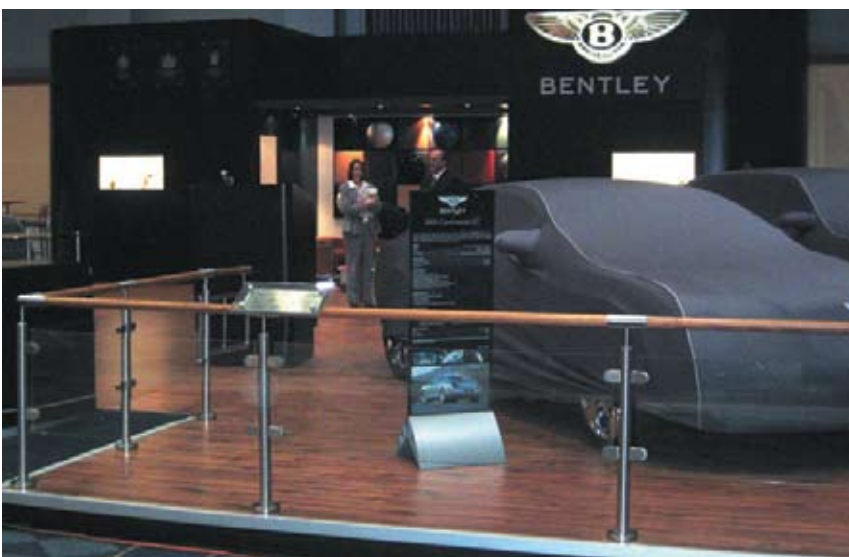

Bridco stainless steel modular handrails are perfect when a barrier is needed for your exhibition show case.

Our staff can pre-cut and assemble your railing partitions to suit your individual show case requirements.

Your partition can be couriered to the venue of your choice ready for installation.

Our experienced staff will be happy to assist you with your partition needs.

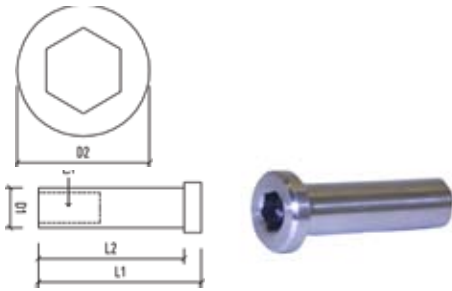

TENSIONER - ALLEN KEY HEAD AISI 316

CODE	D1	D2	L1	L2	G
SS-7500-05	8	12	33	30	M5
SS-7500-06	8	12	40	35	M6

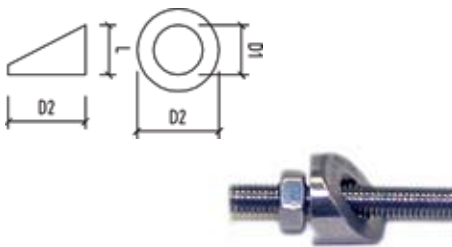

STAINLESS STEEL BEVELLED WASHER AISI 316

CODE	D1	D2	ANGLE	L
SS-7702-01	6	13	35deg	11
SS-7702-02	8	13	35deg	11

Above item to be used with a bevelled washer for angles.

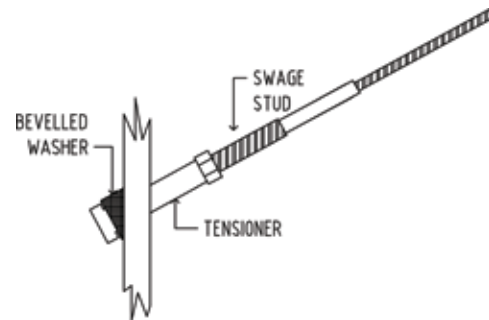
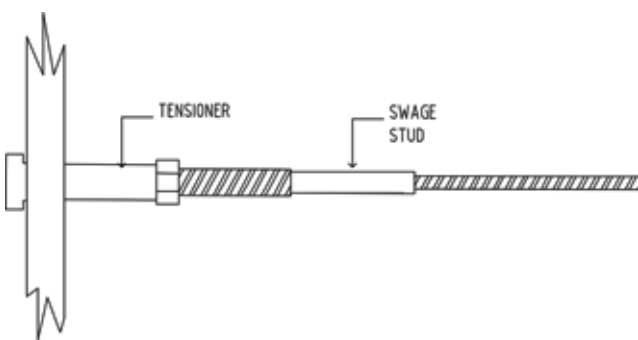

For use on stairways where a through post fitting such as a tensioner or terminal is being used. SS-7702-02 can be used with BRIDCO tensioner SS-7500.

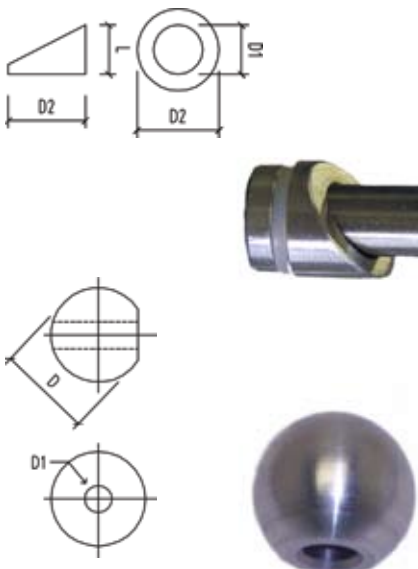

NYLON WASHER TO SUIT TENSIONERS

CODE	TO SUIT
NR-WASH-08NYL	SS-7500-05 / SS-7500-06

ARCHITECTURAL BALL AISI 316

CODE	D	D1	D2
SS-7701-503	15	5.3	10
SS-7701-604	20	6.3	11

STAINLESS STEEL FITTINGS

Telephone (07) 55 93 56 88

PULLEYS FOR CONTINUOUS CABLES - FLAT RAIL

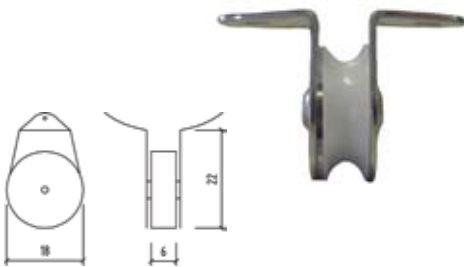

CODE	SHEAVE	DESCRIPTION
SR-8240-00	NYLON	TO SUIT FLAT SURFACES

PULLEYS FOR CONTINUOUS CABLES - ROUND RAIL



CODE	SHEAVE	DESCRIPTION
SR-8240-50	NYLON	TO SUIT ROUND SURFACE 50mm DIA

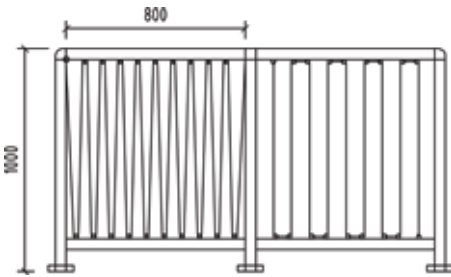

Post Distance 800mm Max
 Height 1000mm Max
 Pulley Centre 80mm Max
 Tension Required 32.2kg Min
 Wire Size 2.5mm
 Wire Construction 7x7 or 7x19



FORK TERMINAL AISI 316

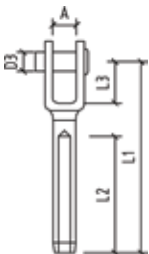

CODE	WIRE DIA		D3	L1	L2	L3	A
	MET	IMP					
*SS-7803X-025	2.5	3/32"	5	45	28	11.5	7
*SS-7803-225	2.5	3/32"	5	60	45	11.5	7
*SS-7803-905		1/8"	5	45	28	11.5	7
SS-7803-305		1/8"	5	67	40	11.5	7
SS-7801M-305	3		5	67	40	12	7
SS-7803-03		1/8"	6	65	32	13	8
SS-7803M-03	3		6	65	32	13	8
SS-7803-406	4	5/32"	6	73	45	15	8
SS-7803-04	4	5/32"	8	77	46	15	11
SS-7803-05		3/16"	9	87	51	18	11

INTERNAL THREAD TERMINAL AISI 316

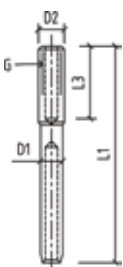

CODE	WIRE DIA	L1	D1	D2	L3	G
SS-7811-503	1/8"	88	6.35	8	35	M5
SS-7811-604	5/32"	95	7.5	8	35	M6

FLAT HEAD TERMINAL AISI 316

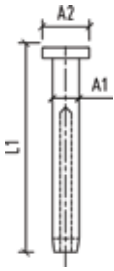

CODE	WIRE DIA	A1	A2	L1
SS-7840-03Z	1/8"	6.35	10	48.5
SS-7840-04	5/32"	7.5	12	59

CONE HEAD TERMINALS AISI 304

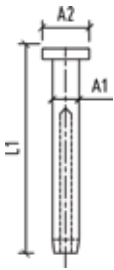

CODE	WIRE DIA	A1	A2	L1
SS-7841-03	1/8"	6.3	10	48.5

SWAGE STUDS - THREADED TERMINAL AISI 316

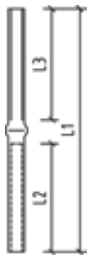

CODE	WIRE DIA		THREAD	L1	L2	L3 THREAD
	MET	IMP				
SS-7801-03L		1/8"	M6 LEFT	91	40	40
SS-7801-03M		1/8"	M6	91	40	40
SS-7801M-03M	3		M6	97	40	48
SS-7801M-03ML	3		M6LONG	118	40	75
SS-7801-03ML		1/8"	M6LONG	118	40	75
SS-7801-03MY		1/8"	M6	100	52	42
SS-7801-305		1/8"	M5	91	40	40
SS-7801-020		1/8"	M5	59	33	22.5
SS-7801M-020	3		M5	58.7	34	22.5
SS-7801M-305M	3		M5	91	40	40
SS-7801-305L		1/8"	M5LEFT	90	40	40
SS-7801-04L	4	5/32"	M8LEFT	118	43	57
SS-7801-04M	4	5/32"	M8	120	47	60
SS-7801-04ML	4	5/32"	M8LONG	143	47	90
SS-7801-046	4	5/32"	M6	116	46	50
SS-7801-046L	4	5/32"	M6LEFT	116	46	50
SS-7801-05L		3/16"	M8LEFT	121	58	57
SS-7801-05M		3/16"	M8	121	53	60
SS-7801-510		3/16"	M10	129	56	60
SS-7801-05ML		3/16"	M10LONG	177	58	115
SS-7801-06M		1/4"	M12	181	67	105
SS-7801M-06M	6		M12	162	67	78
SS-7801M-06ML	6		M12LONG	222	67	143

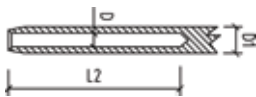

WIRE SIZE	D +0.2	D1 +0.05	D1 AFTER SWAGING
3/32"	2.8	5.5	4.7 - 4.82
1/8"	3.5	6.35	5.44 - 5.56
5/32"	4.4	7.5	6.23 - 6.35
3/16"	5.1	9.	7.83 - 7.95
7/32"	5.8	10.8	9.35 - 9.50
M6	6.5	12.5	10.95 - 11.12
1/4"	6.8	12.5	10.95 - 11.12
5/16"	8.4	16	14.07 - 14.3
3/8"	10	17.8	15.7 - 15.9
M10	10.5	17.8	15.7 - 15.9
M12	12.5	21.4	18.82 - 19.05
1/2"	13.5	21.4	18.82 - 19.05
M14	14.8	25	22.00 - 23.23
5/8"		28	25.15 - 25.40

STAINLESS STEEL FITTINGS

Telephone (07) 55 93 56 88

BUTTON HEAD SOCKET SCREW



CODE	HEAD DIA	LENGTH	THREAD
SS-98-05	9	30	M5
SS-98-06	10	40	M6

HAMMER PINS AISI 316



CODE	SIZE	LENGTH	TO SUIT
SS-HP-05	M5	11	SS-7803-305 SS-312T-503
SS-HP-06	M6	13	SS-7803-03 SS-312T-604

BOTTLESCREWS - JAW & SWAGE STUD AISI 316



CODE	THREAD SIZE	TO SUIT WIRE	L1		H	A	PIN DIA	TDL KG
			MIN	MAX				
*SS-312TX-025	M5	3/32"	109	149	11.5	6	5	600
*SS-312T-020	M5	1/8"	109	149	11.5	6	5	600
SS-312T-503	M5	1/8"	153	193	11.5	6	5	600
SS-312T-604	M6	5/32"	177	225	12.5	8	6	1000
SS-312T-635	M6	1/8"	167	207	12.5	8	6	1000

* Indicates mini fittings. Both mini bottle screws are pressed with HEX 3 dies.

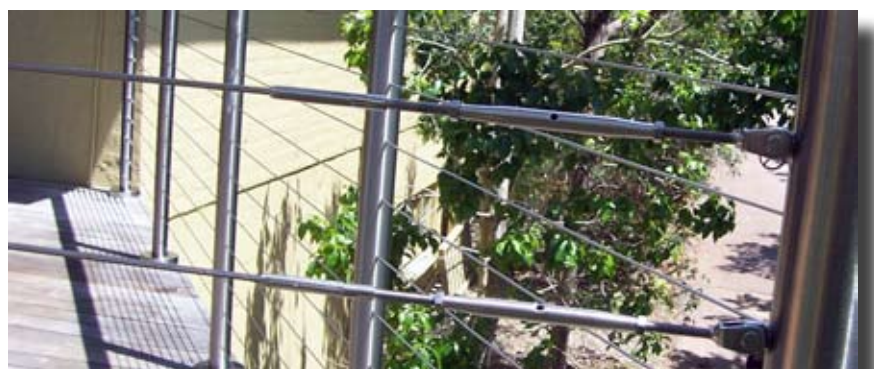

BOTTLESCREW - TOGGLE & SWAGE STUD

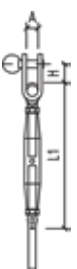

CODE	THREAD SIZE	TO SUIT WIRE	L1		H	A	PIN DIA	TDL KG
			MIN	MAX				
SS-3121T-63	M6	1/8"	142	215	12	8	6	940
SS-3121T-64	M6	5/32"	142	215	12	8	6	940
SS-3121T-84	M8	5/32"	180	260	12.5	11.5	8	1800

STAINLESS STEEL FITTINGS

www.bridco.com.au

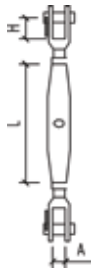

BOTTLESCREW - JAW & JAW WITH LOCK NUTS AISI 316

CODE	DIA	LENGTH		A	H	L	TDL KG
		MIN	MAX				
SS-312J-05	M5	125	185	7.5	11.5	80	750
SS-312J-06	M6	140	215	8.3	12.5	90	1400
SS-312J-08	M8	165	250	11.8	15.5	105	2200



BOTTLESCREW - TOGGLE & TOGGLE AISI 316

CODE	DIA	LENGTH		A	H	L	TDL KG
		MIN	MAX				
SS-3125-06	M6	150	200	7.8	15	90	900
SS-3125-08	M8	185	260	11	17	104	1650



BOTTLESCREW - SWAGELESS AISI 316

CODE	THREAD SIZE	TO SUIT WIRE	L1		H	A	PIN DIA	TDL KG
			MIN	MAX				
SS-8014-603	M6	1/8"	163	245	13	8	6	600

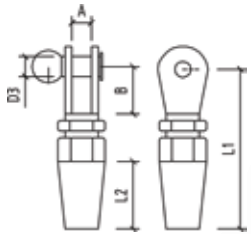

FORK TERMINAL - SWAGELESS AISI 316

CODE	WIRE DIA	A	B	D3	L1	L2
SS-8012-03	1/8"	9	19	5	50	19

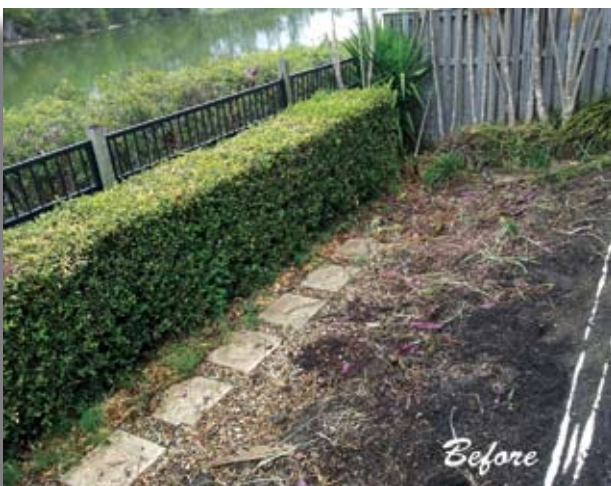

STAINLESS STEEL FITTINGS

Telephone (07) 55 93 56 88

TURNBUCKLES - OPEN BODY - WITH LOCK NUTS

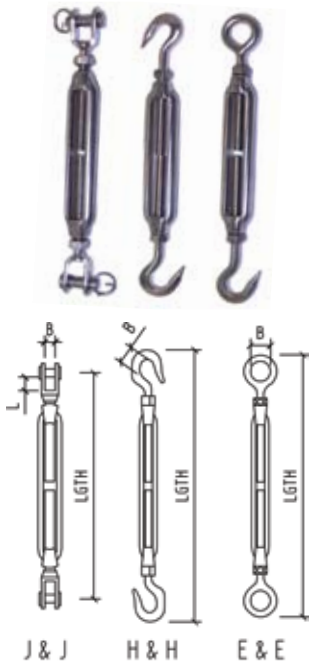

CODE	DIA mm	STYLE	LENGTH		B	L	TDL KG
			MIN	MAX			
SS-311E-04	4	E & E	98	135	8		475
SS-311H-04	4	H & H	98	135	7		100
SS-311HE-04	4	H & E	98	135	8		100
SS-311E-05	5	E & E	120	170	8		680
SS-311H-05	5	H & H	120	170	7		130
SS-311HE-05	5	H & E	120	170	7		130
SS-311J-05	5	J & J	120	160	6	10	680
SS-311E-06	6	E & E	150	220	10		1500
SS-311H-06	6	H & H	160	220	9		350
SS-311HE-06	6	H & E	155	220	9		350
SS-311J-06	6	J & J	150	200	7	9	1500



GROMMETS

Bridco have a range of grommets to be used when passing wire through steel, aluminium or even timber posts. These UV stabilised, high density polythene grommets give a neat appearance as well as protection from chafe and electrolysis.

For further information on sizes and dimensions please refer to the Bridco product catalogue or visit our website www.bridco.com.au and follow the link to download the catalogue.





Importers and Wholesalers of Stainless Steel Hardware and Wire Rope Fittings,
Swage Presses and Associated Machinery.



37 TAREE STREET
BURLEIGH QLD 4220

TELEPHONE (07) 55 935 688
FAX (07) 55 935 872

WEB: www.bridco.com.au
EMAIL: bridge@bridco.com.au

BRIDGE & COMPANY PTY LTD



We Have,
Distributors Throughout Australia

First Edition - June 2013

Bridge & Company Pty Ltd. ABN 79 010 586 857

